

Part Reference	Description
PP-CALY-EA-QU-GR	Calypso Chime Quatro Post (Each) (Ground Fix)

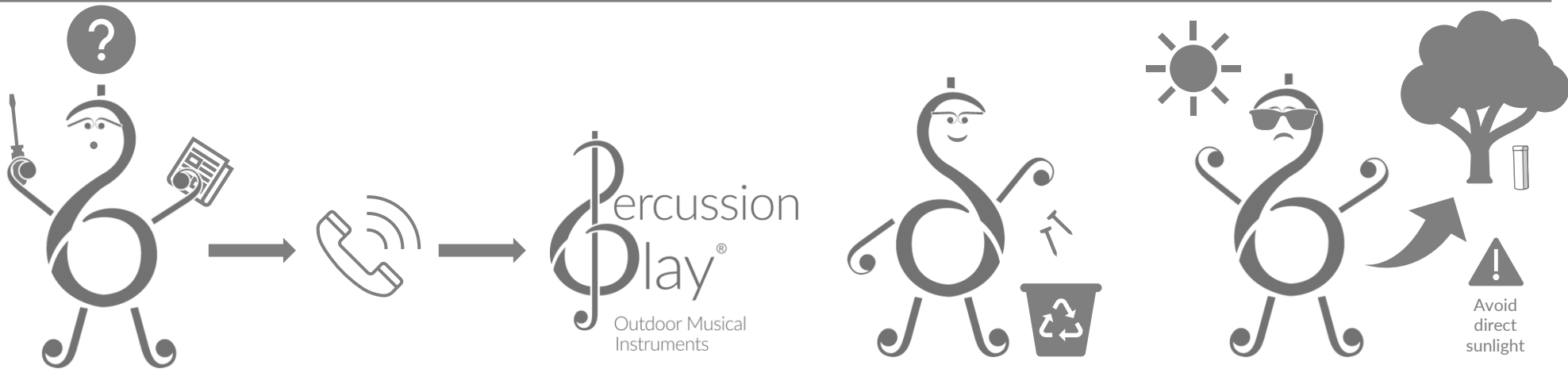

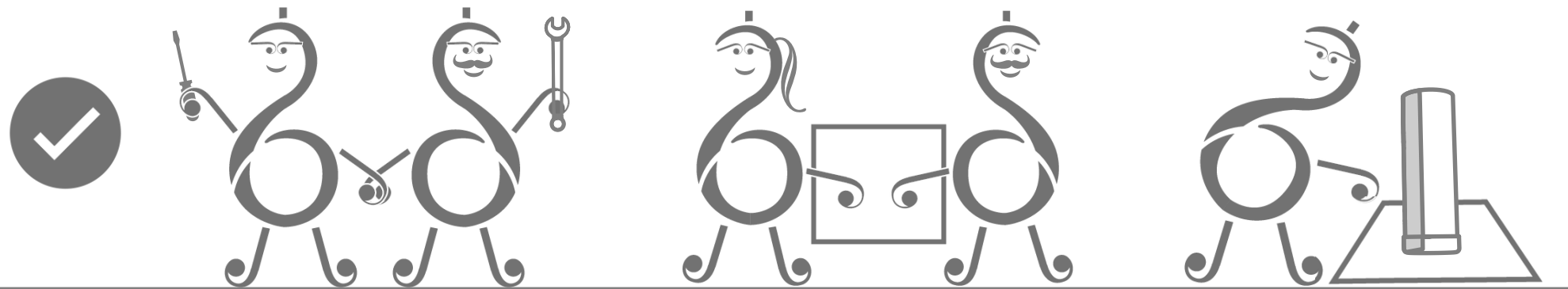

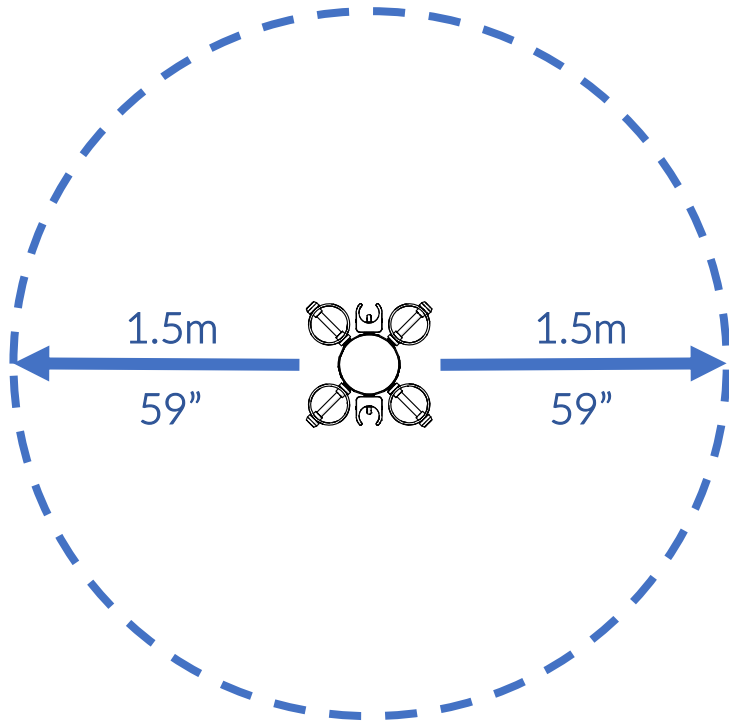

Check Risk Assessment

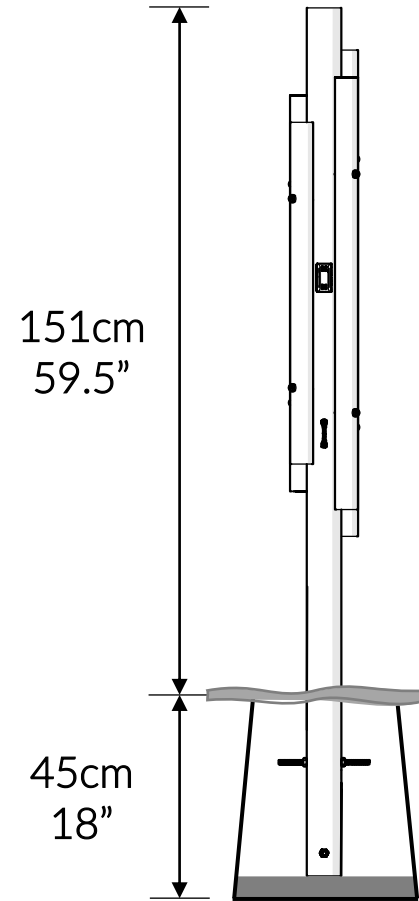

Packages

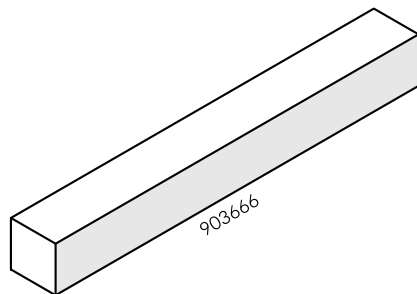

x1

		L	W	H	Weight	Net
x1	903666	195cm / 77"	24cm / 9.5"	24cm / 9.5"	13kg / 28.5lbs	

Tools required (not supplied)

¼" Bit Driver Ratchet



11/16" / 17mm Spanner



x2



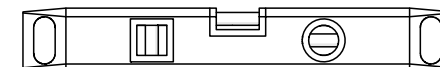

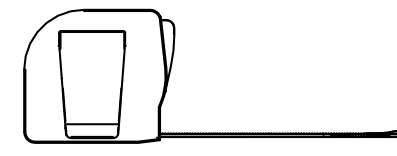

Spirit level

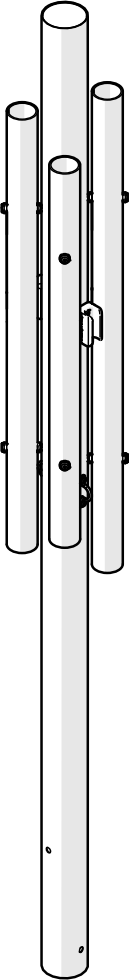

Tape Measure

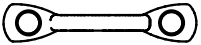
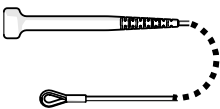

Not to scale

903666		
 <p>① x1</p>	<p>Ⓐ x4 500457</p> 	<p>Ⓑ x2 500627</p> 
	<p>Ⓒ x4 500746</p> 	
	<p>Ⓓ x2 603150</p> 	
	<p>② x2 900837</p> 	
	<p>x1 TX30 500473</p> 	

1.

1.1

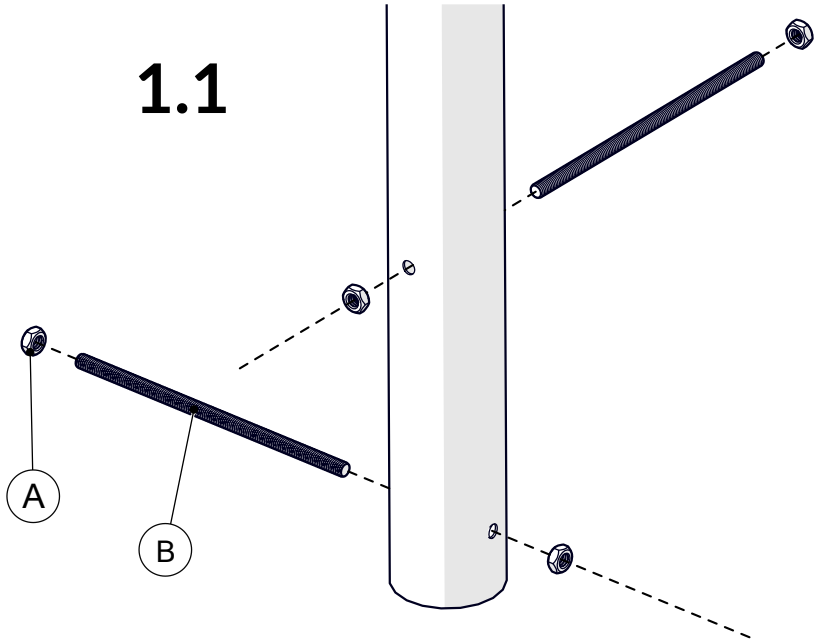

1.2

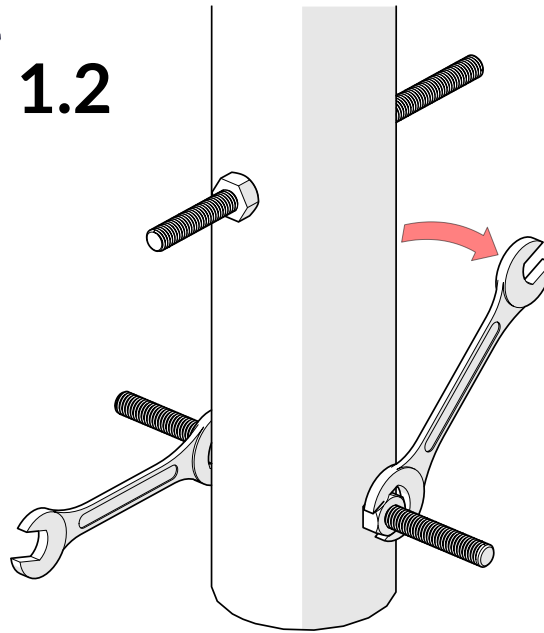

1.3

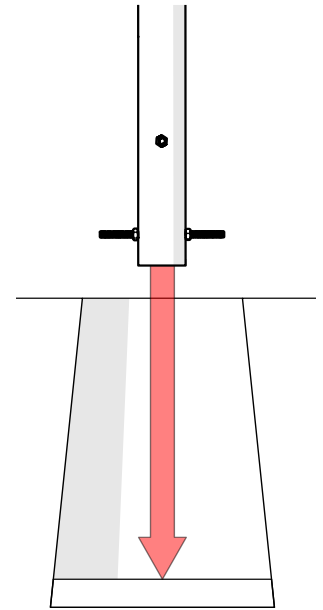

A		x4
B		x2

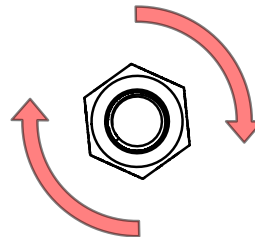

2.



Foundations should not present a hazard

Refer to your local Health & Safety standards

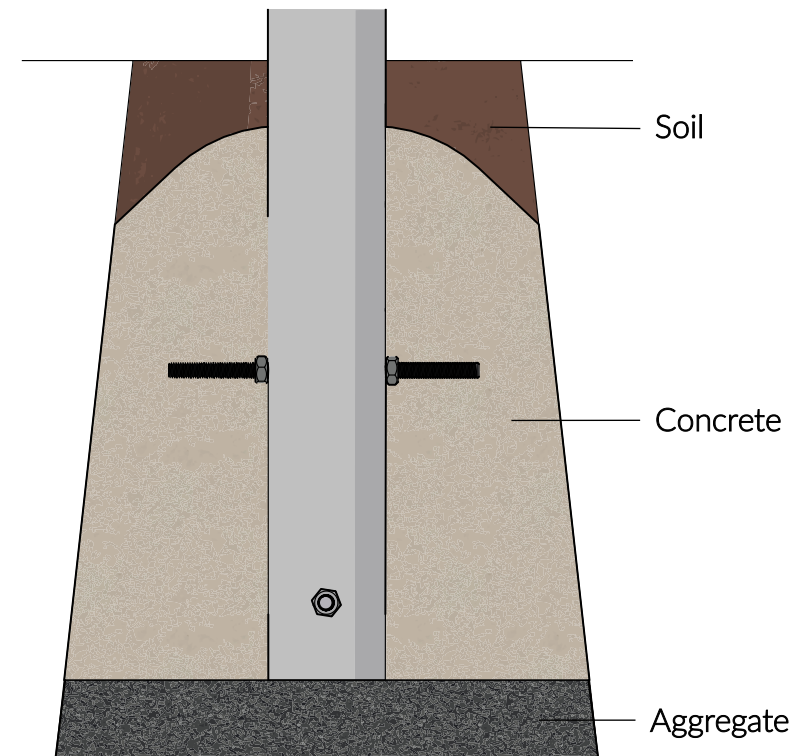
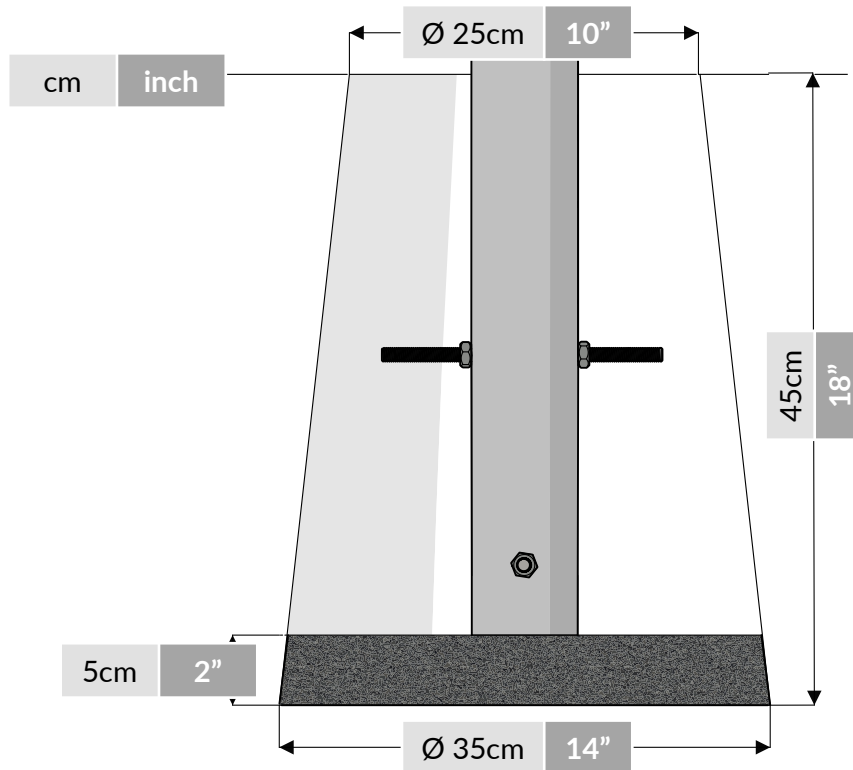
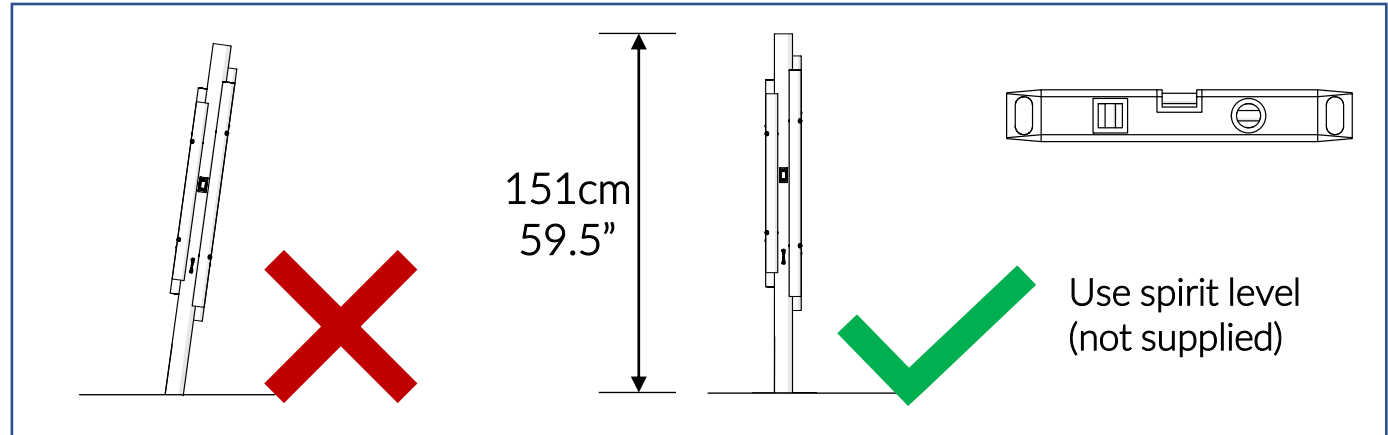

3.

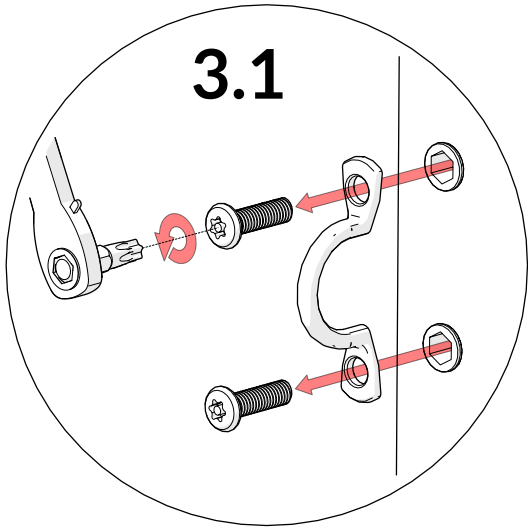

3.1

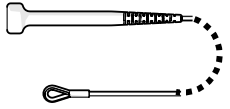
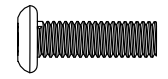
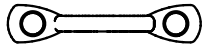

TX30

2		x2
C		x4
D		x2

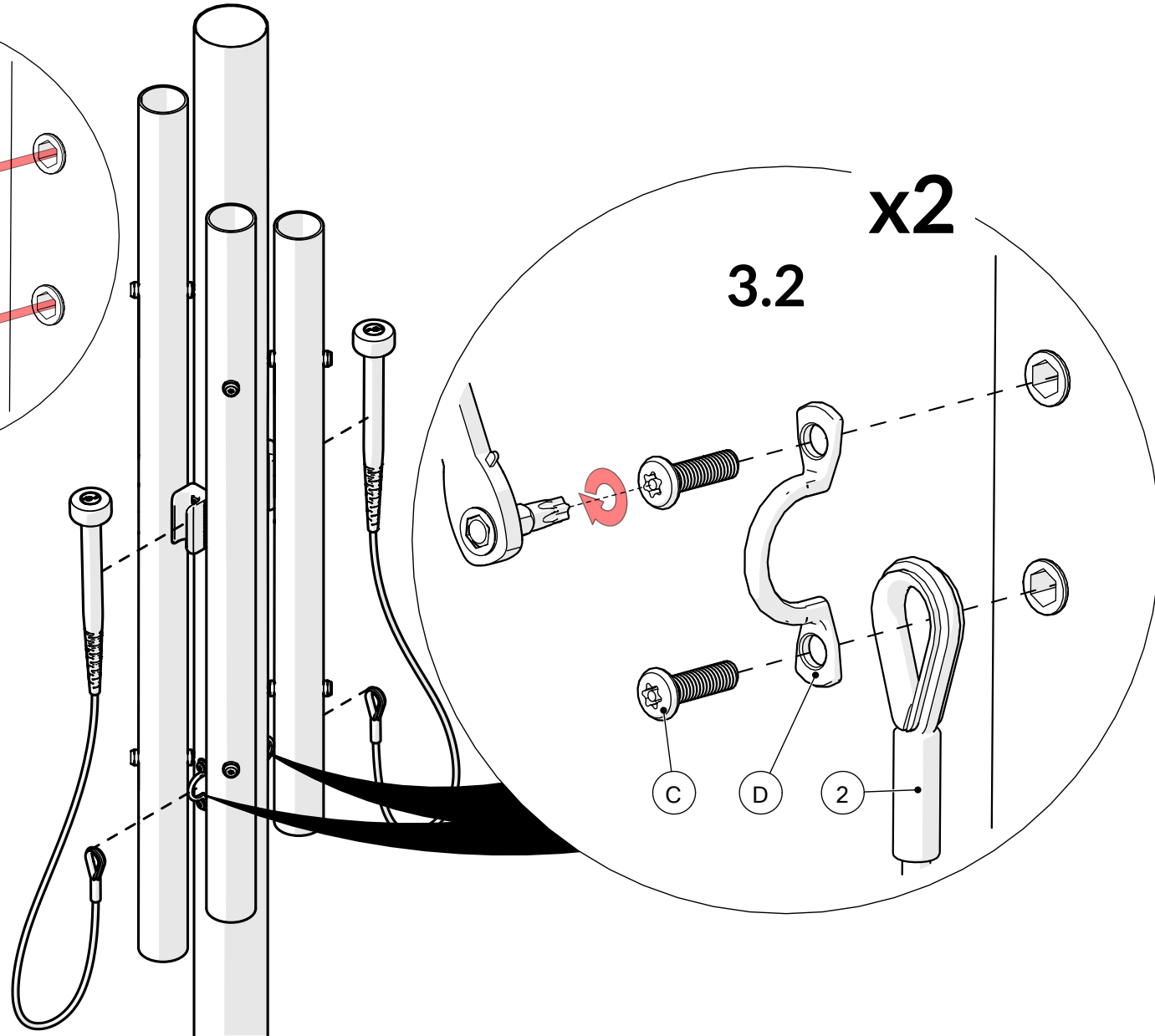

3.2

x2

C

D

2

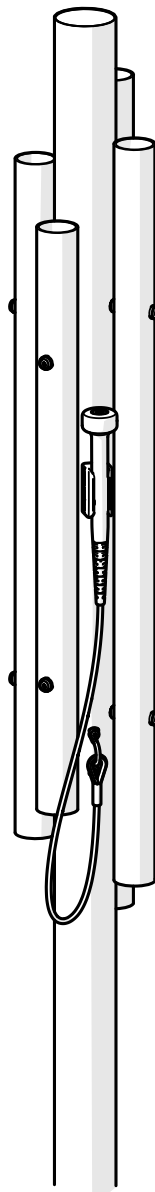

percussionplay.com



info@percussionplay.com



UK
[01730 235 180](tel:01730235180)

USA & CAN
[+1 \(866\) 882 9170](tel:+18668829170)

EUR & ROW
[+44 1730 235 180](tel:+441730235180)