

Part Reference	Description
PP-CALY-EA-QU-SU	Calypso Chime Quatro Post (Each) (Surface Fix)

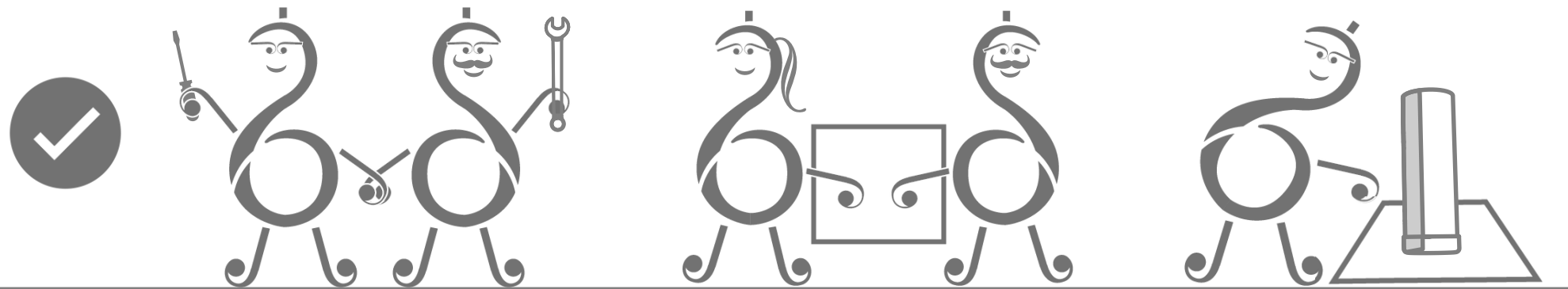

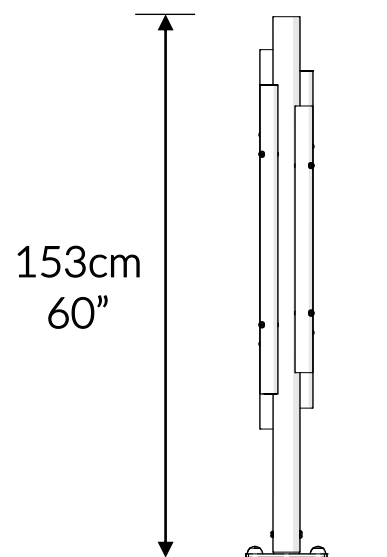

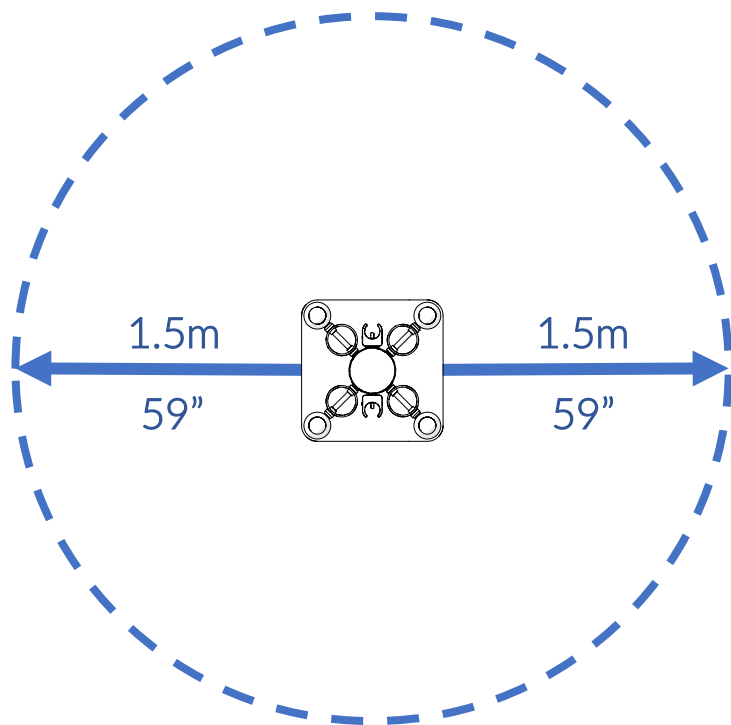

Check Risk Assessment

Packages

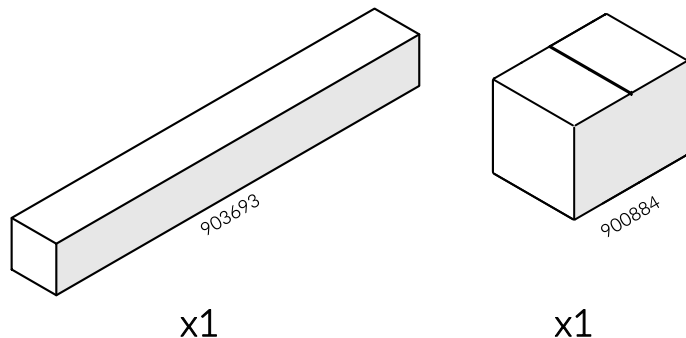

		L	W	H	Weight	Net
x1	903693	195cm / 77"	24cm / 9.5"	24cm / 9.5"	13kg / 28.5lbs	
x1	900884	32cm / 12.5"	23cm / 9"	23cm / 9"	6kg / 13lbs	



Tools required (not supplied)

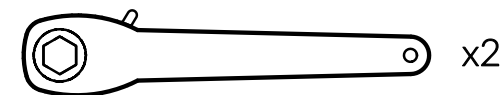

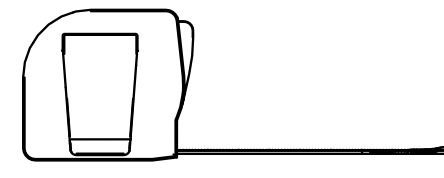

¼" Bit Driver Ratchet

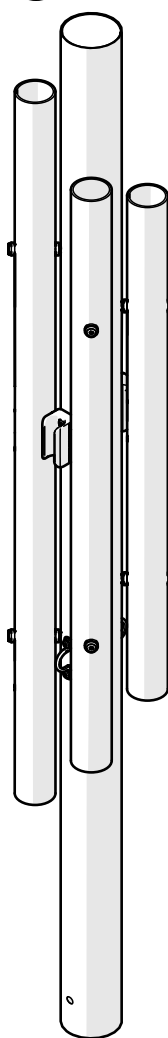
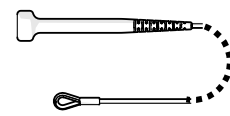
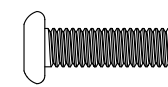
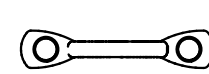

Tape Measure

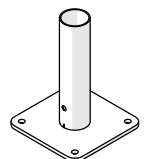

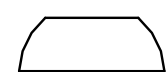
903693	
<p>① x1</p> 	<p>② x2 900837</p> 
	<p>⑤ x4 500746</p> 
	<p>⑥ x2 603150</p> 
	<p>x1 TX30 500473</p> 

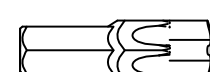
900884	
<p>③ x1 800878</p>	
<p>Ⓐ x1 500667</p>	
<p>Ⓑ x1 500613</p>	
<p>Ⓒ x4 601543</p>	
<p>Ⓓ x4 601542</p>	
<p>TX45 x2 500720</p>	

Not to scale

1.

1.1

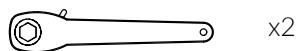
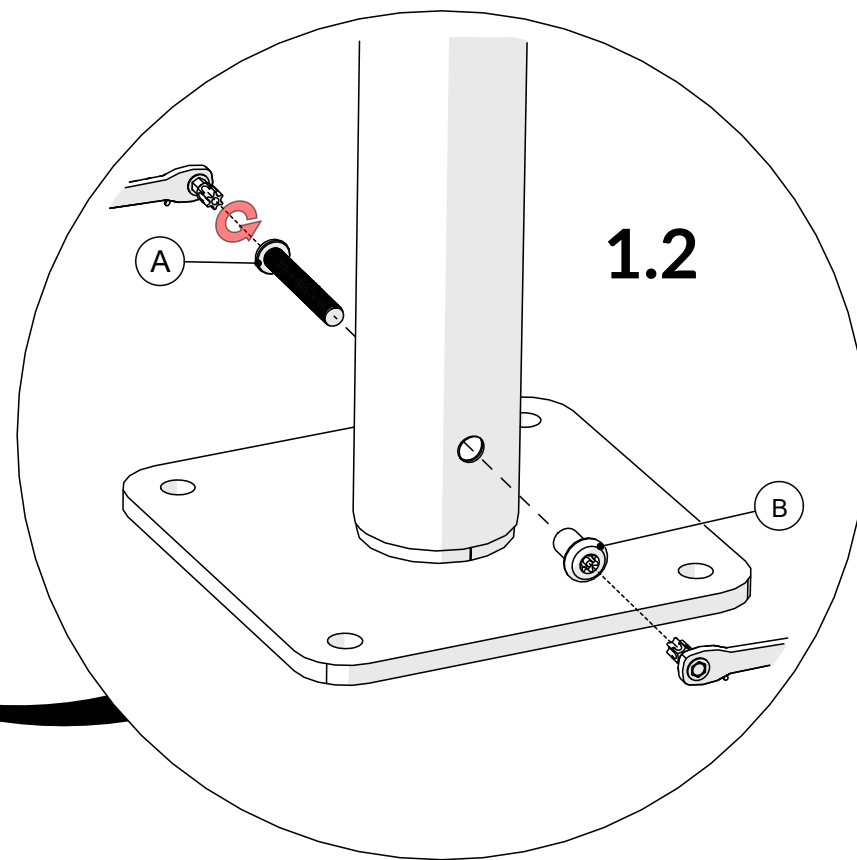
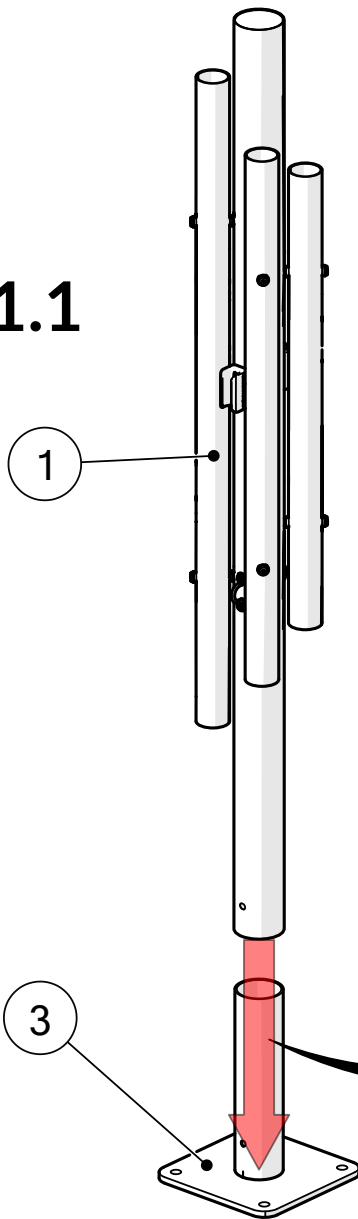

x2

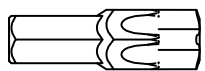

x2 TX45

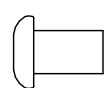
A		x1
B		x1

2.



Surface fixing should not present a hazard

Refer to your local Health & Safety standards

C		x4
D		x4

Surface

Example fixing

	Wood		x4
	Concrete		x4
	Brick		x4

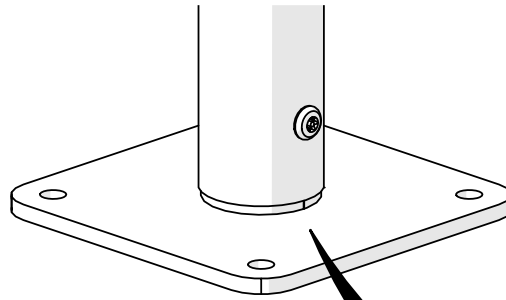

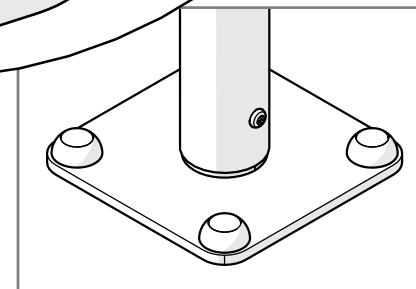
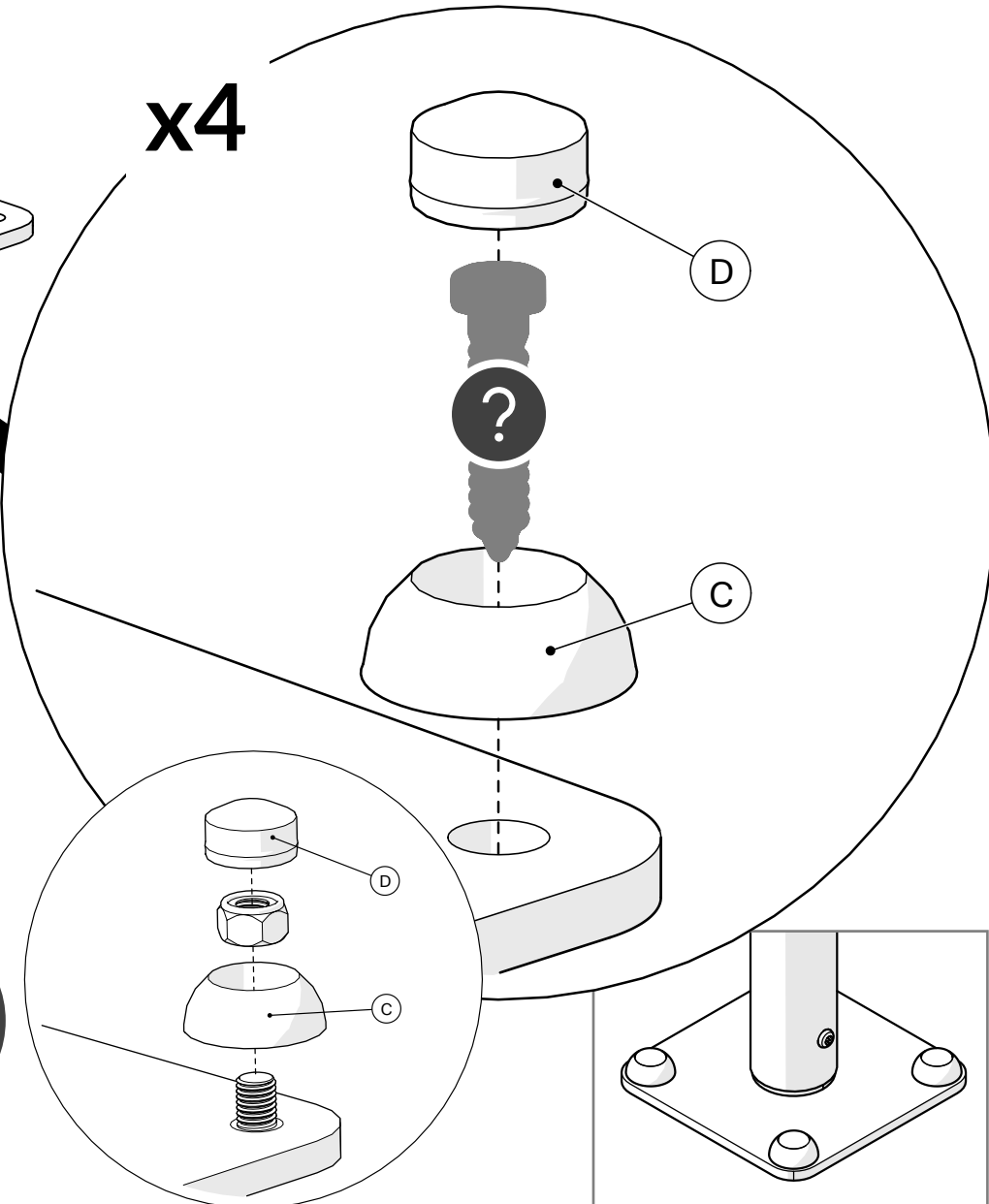

x4

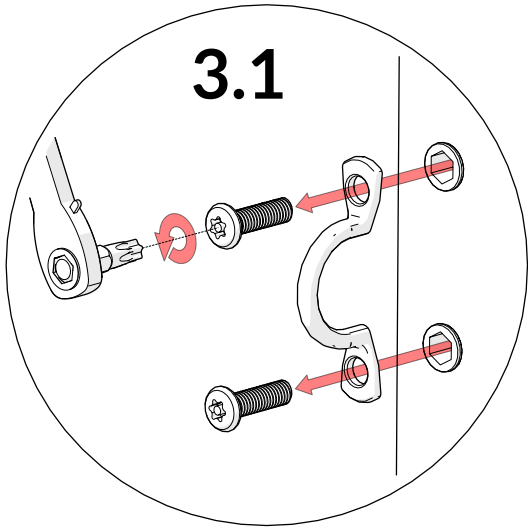

3.

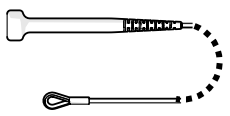

TX30

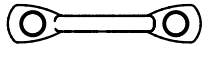
2		x2
E		x4
F		x2

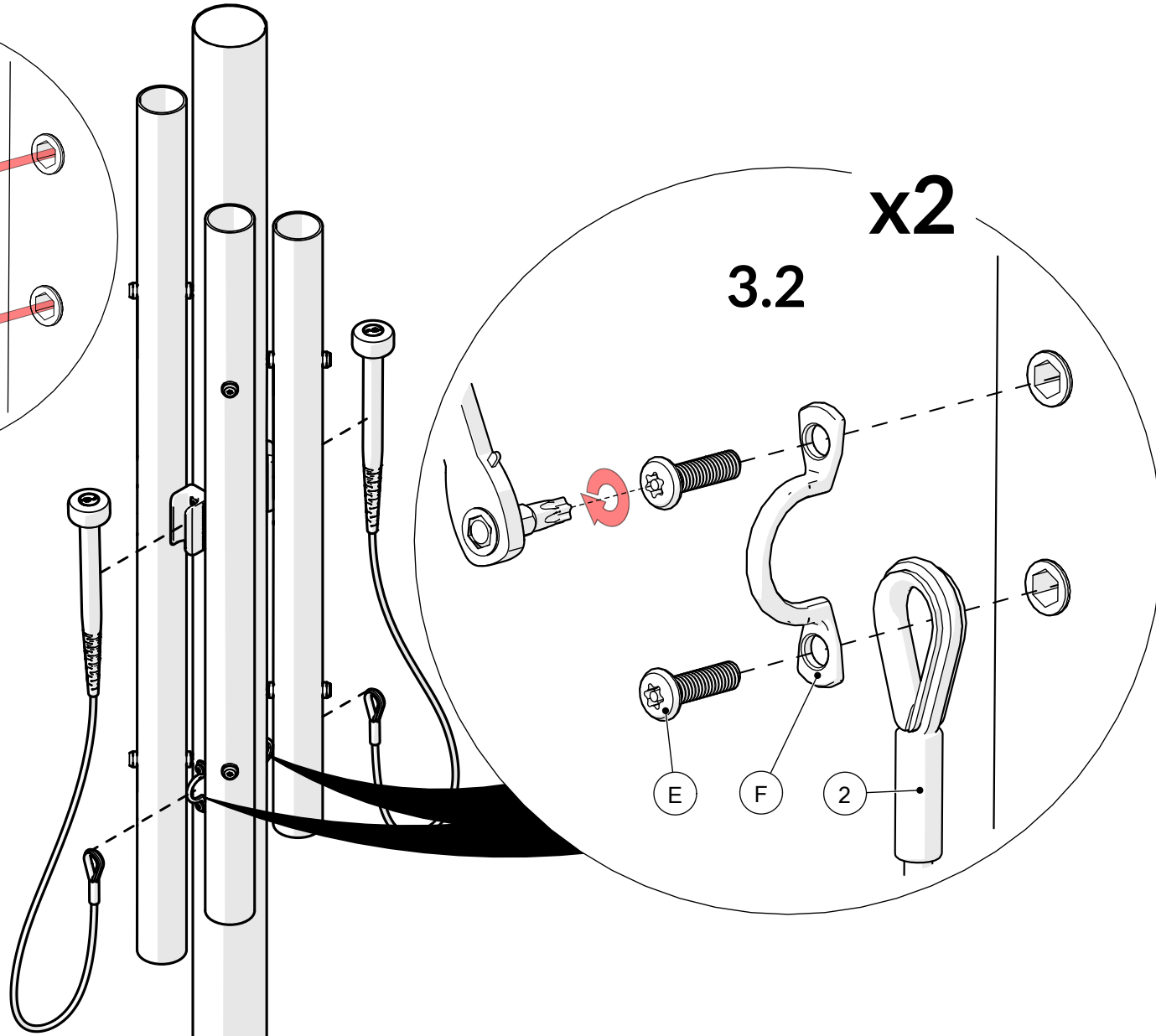

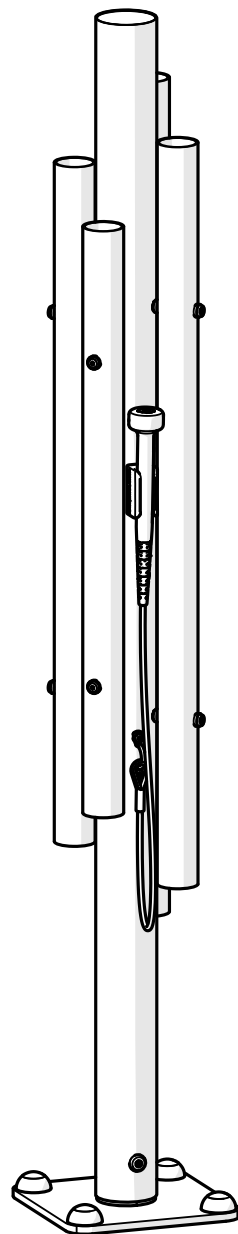

percussionplay.com



info@percussionplay.com



UK
[01730 235 180](tel:01730235180)

USA & CAN
[+1 \(866\) 882 9170](tel:+18668829170)

EUR & ROW
[+44 1730 235 180](tel:+441730235180)