

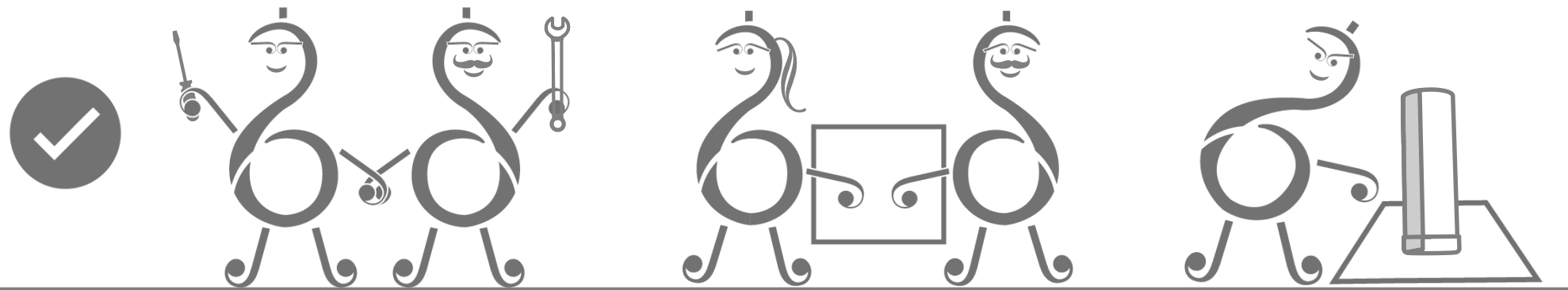

Part Reference	Description
PP-CYCL-SU	Cyclone (Surface Fix)

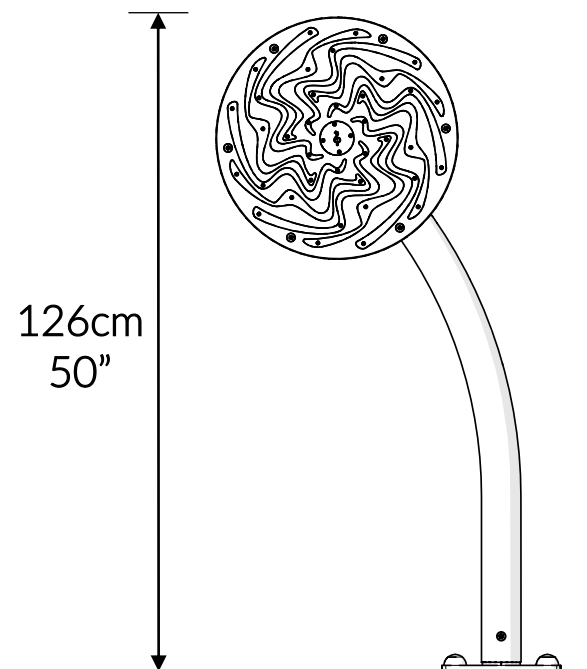

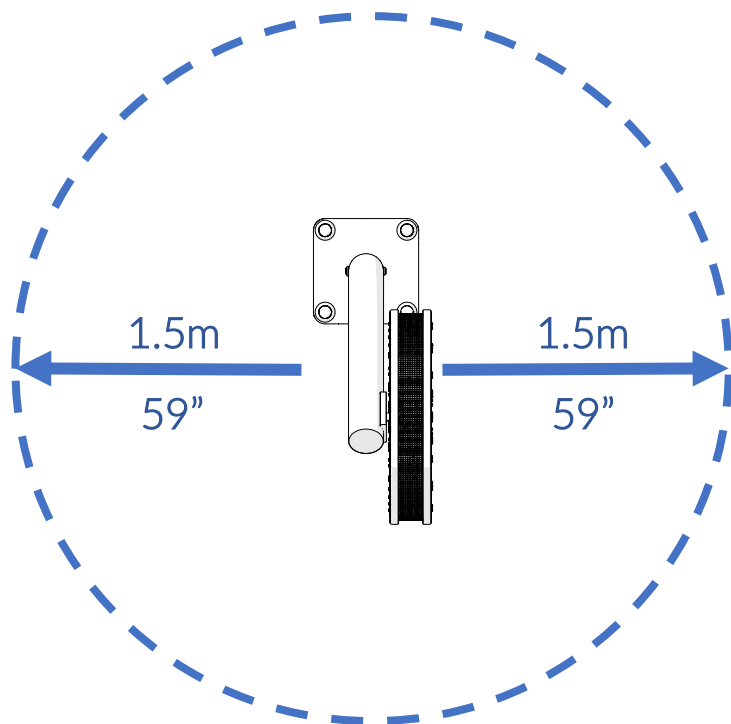



Check Risk Assessment

Packages

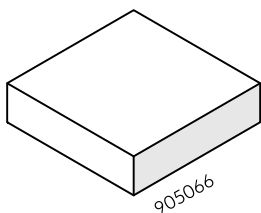

x1

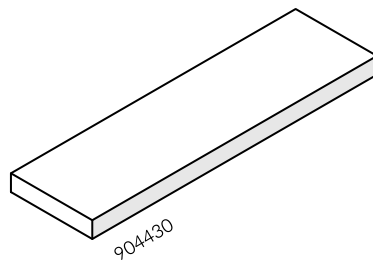

x1

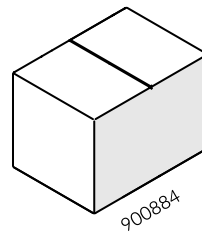

x1

		L	W	H	Weight	Net
x1	905066	60cm / 24"	60cm / 24"	16cm / 6"	6kg / 13lbs	
x1	904430	140cm / 70"	40cm / 16"	8cm / 3"	9kg / 20lbs	
x1	900884	32cm / 12.5"	23cm / 9"	23cm / 9"	6kg / 13lbs	

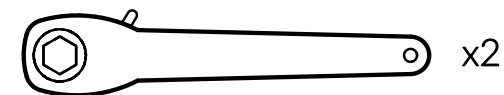

Tools required (not supplied)

¼" Bit Driver Ratchet



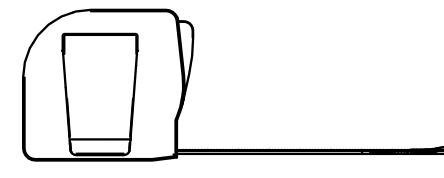

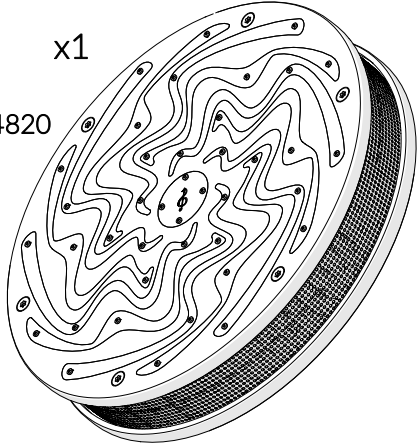

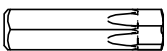
Tape Measure

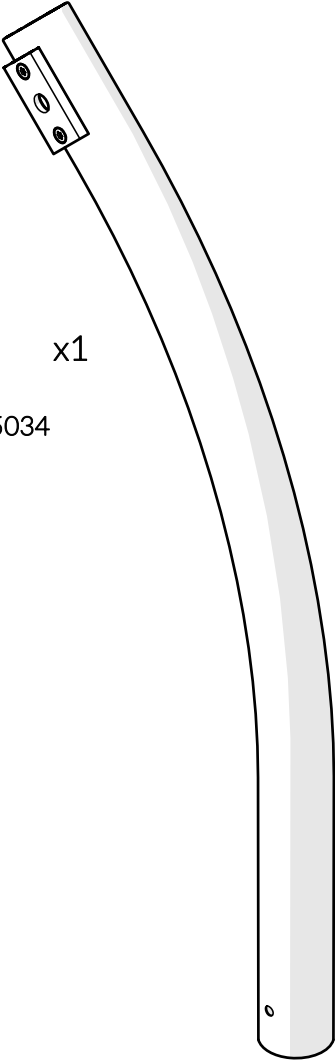

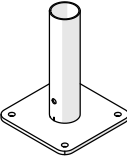
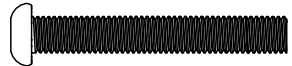
905066	
<p>① x1 804820</p>	
<p>17mm x1 605482</p>	
<p>TX30 x1 500473</p>	
<p>TX40 x1 500474</p>	

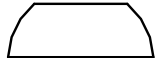
904430	
<p>② x1 805034</p>	

900884	
<p>③ x1 800878</p>	
<p>A x1 500667</p>	
<p>B x1 500613</p>	
<p>C x4 601543</p>	
<p>D x4 601542</p>	
<p>TX45 x2 500720</p>	

1.

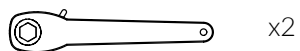

x2

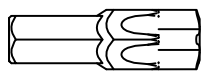

x2 TX45

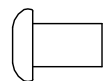
A		x1
B		x1

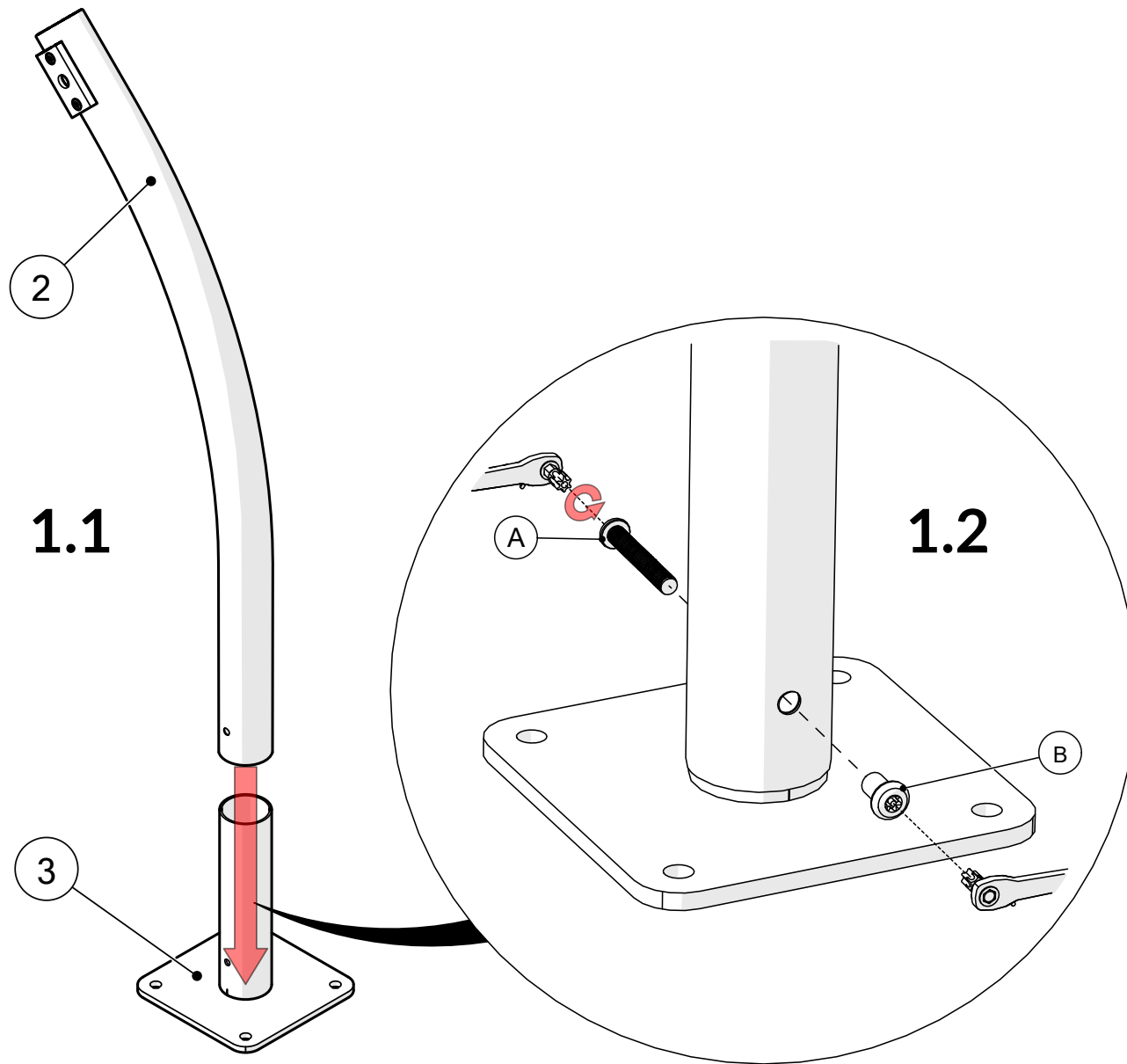

2.

Surface fixing should not present a hazard



Refer to your local Health & Safety standards

C		x4
D		x4

Surface

Example fixing

	Wood		x4
	Concrete		x4
	Brick		x4

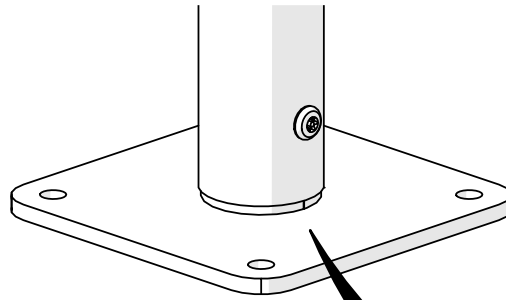

x4

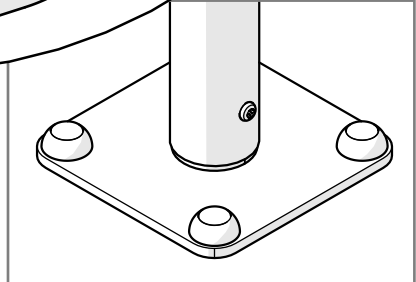
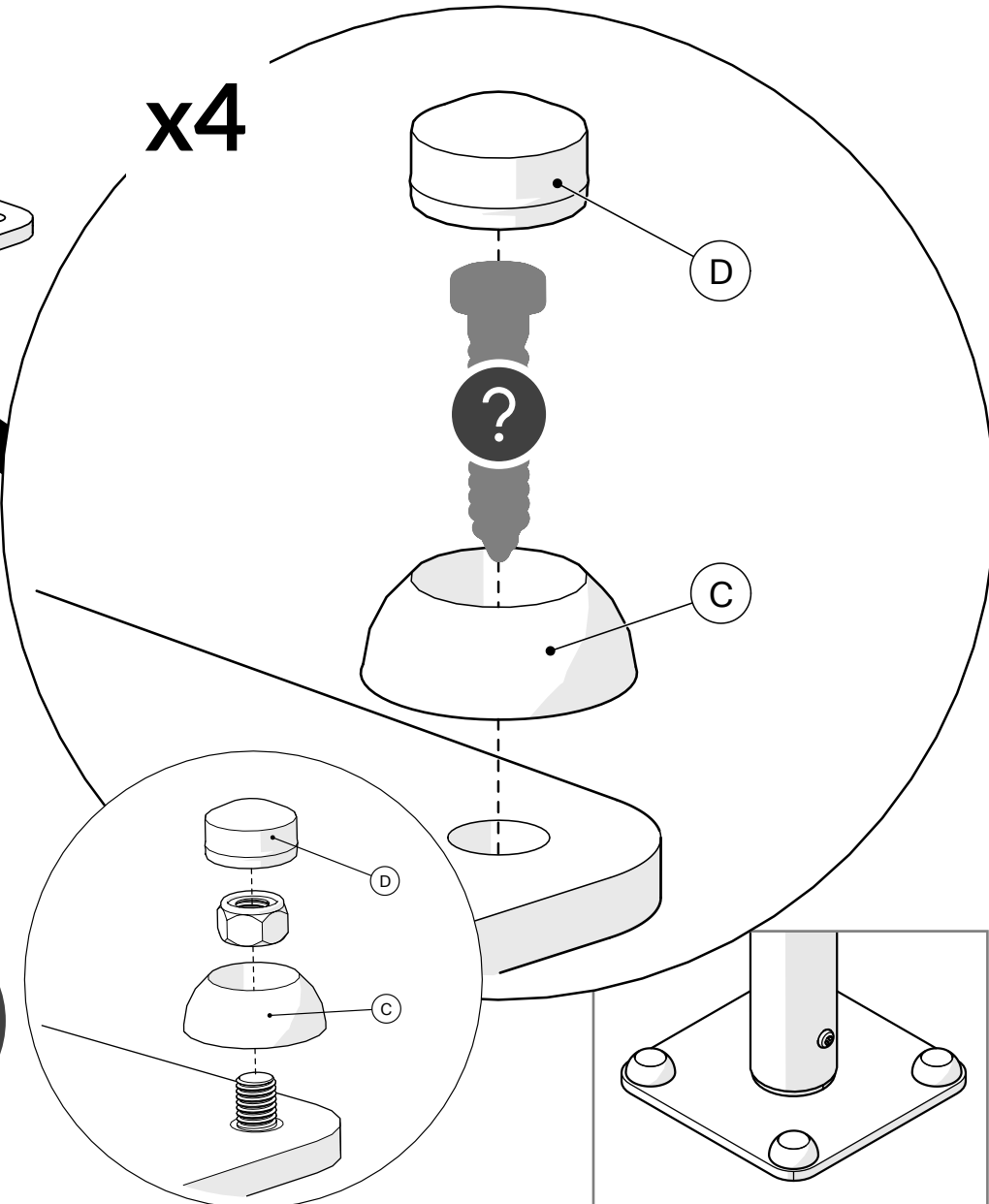

3.

3.1

3.2

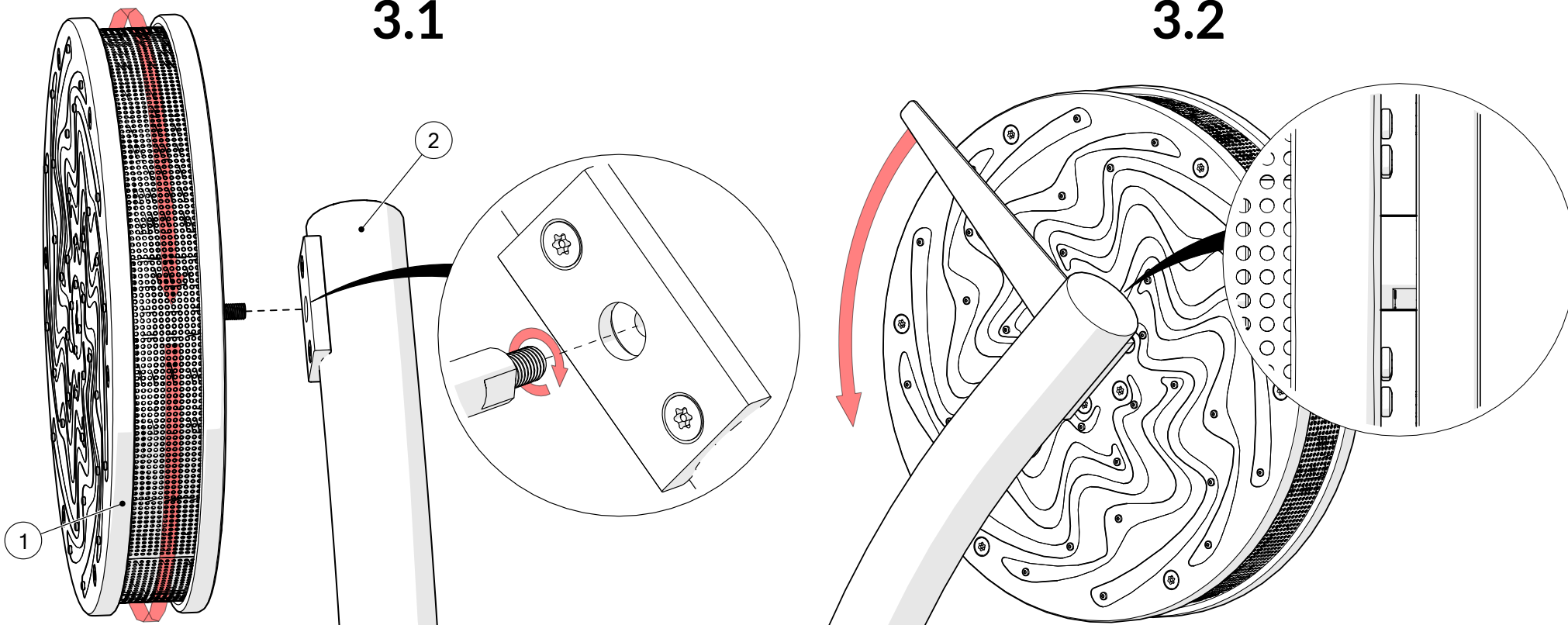

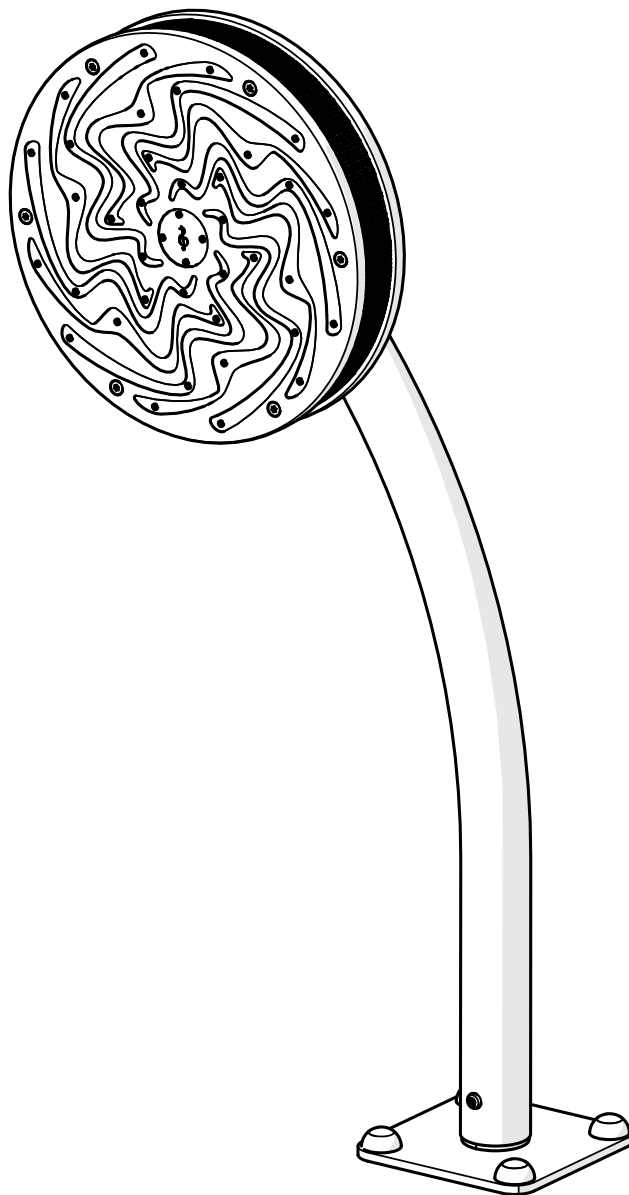

percussionplay.com



info@percussionplay.com



UK
[01730 235 180](tel:01730235180)

USA & CAN
[+1 \(866\) 882 9170](tel:+18668829170)

EUR & ROW
[+44 1730 235 180](tel:+441730235180)