

Part Reference	Description
PP-CYCL-GR	Cyclone (Ground Fix)

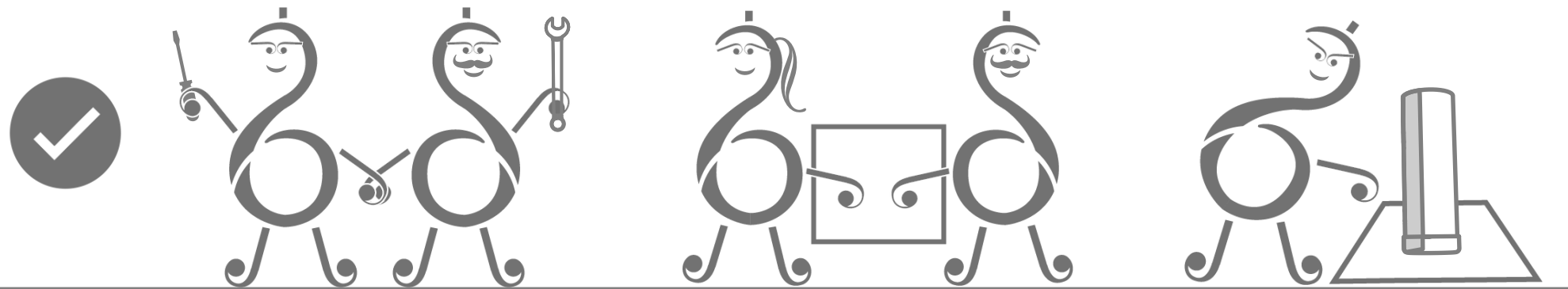

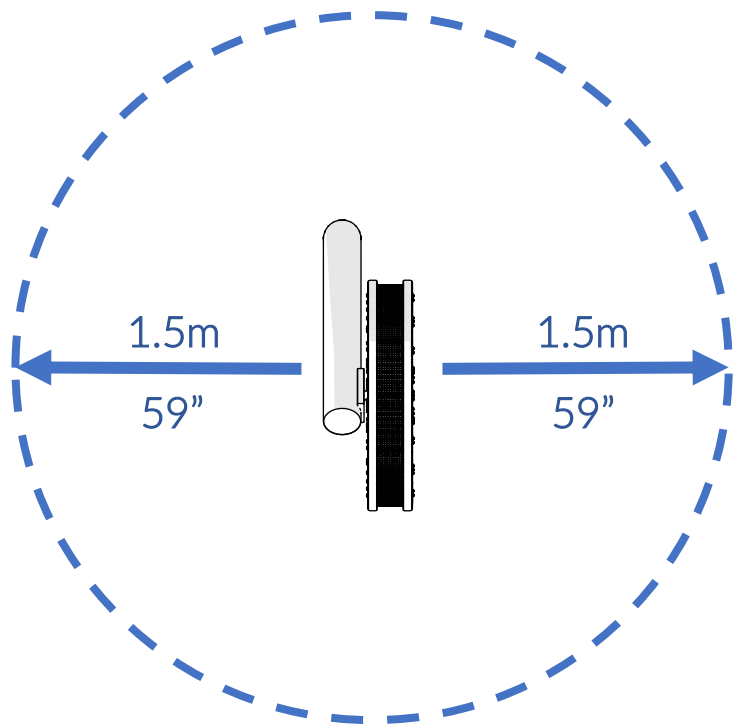



Check Risk Assessment

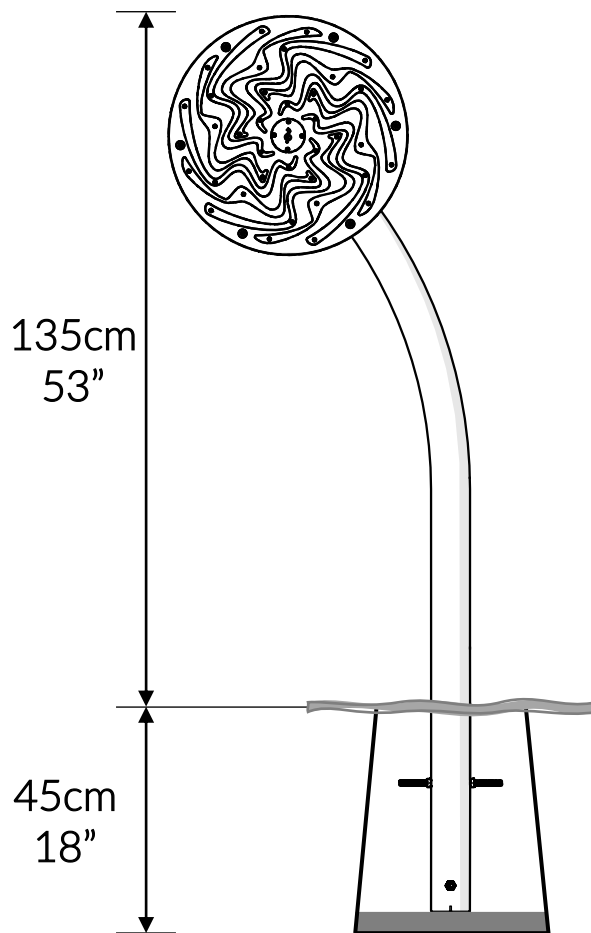

Packages

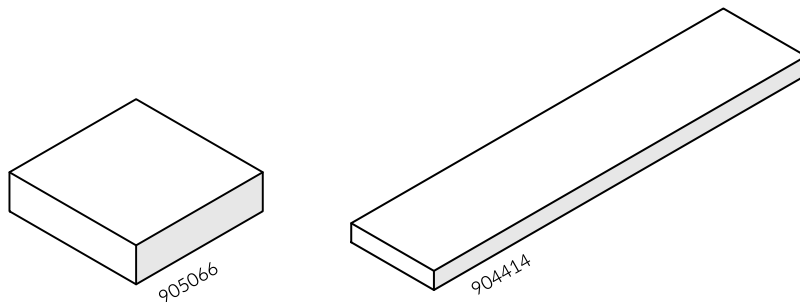

x1

x1

		L	W	H	Weight	Net
x1	905066	60cm / 24"	60cm / 24"	16cm / 6"	6kg / 13lbs	
x1	904414	180cm / 70"	40cm / 16"	8cm / 3"	10kg / 22lbs	

Tools required (not supplied)

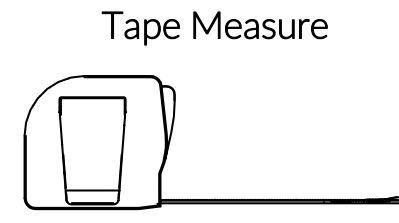
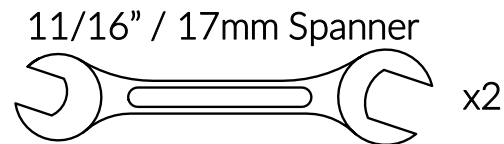

905066

① x1
804820

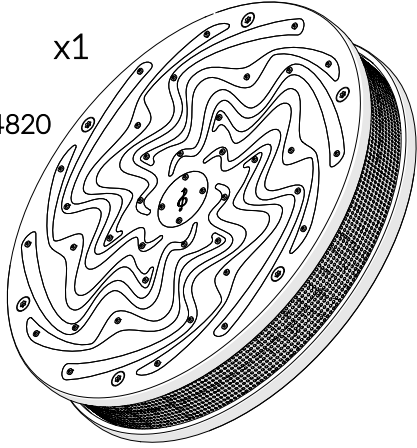

17mm x1
605482



TX30 x1
500473



TX40 x1
500474

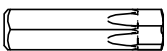

904414

② x1
805033

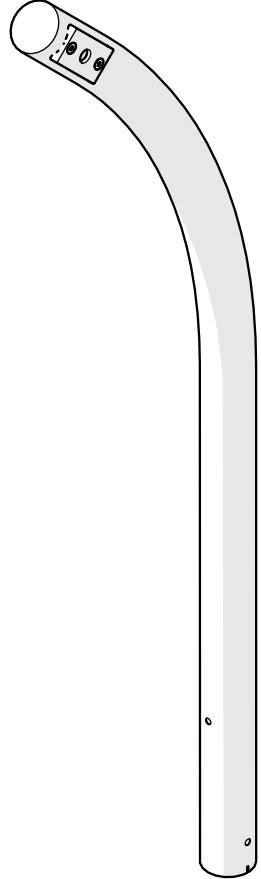

Ⓐ x4
500457



Ⓑ x2
500627



Not to scale

1.

1.1

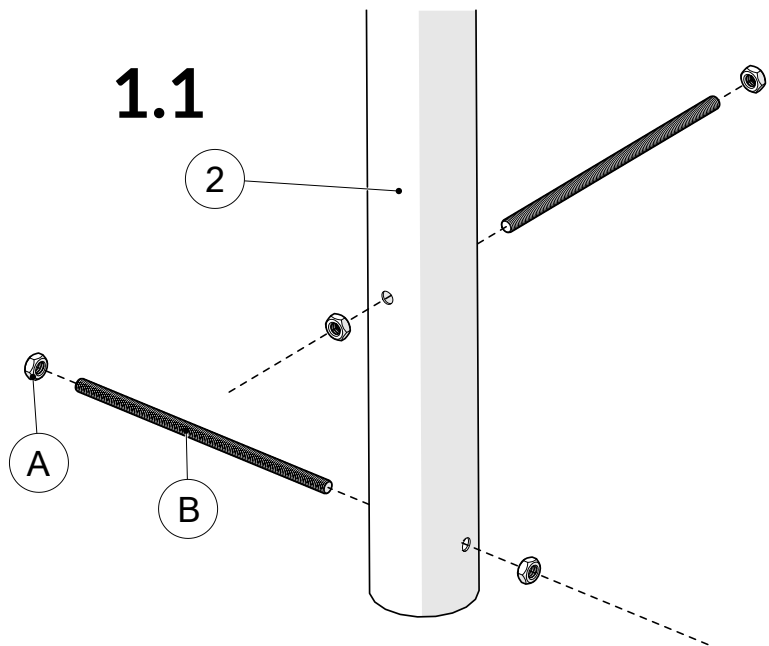

1.2

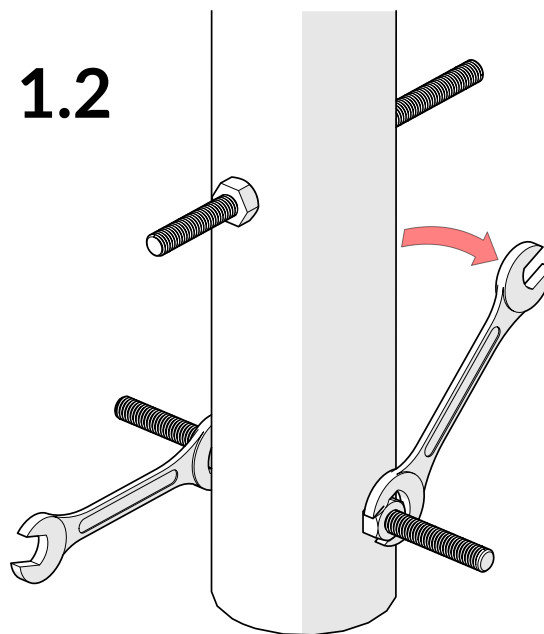

1.3

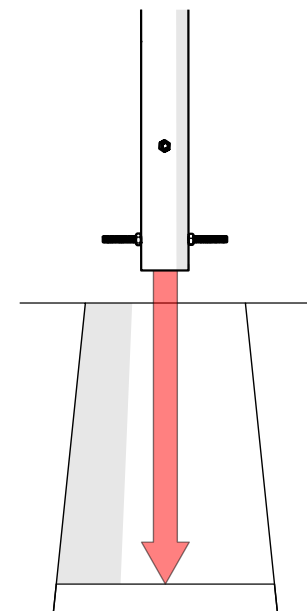

A		x4
B		x2

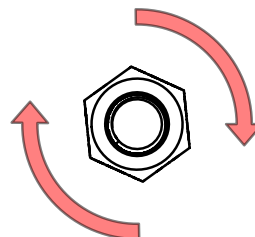

2.



Foundations should not present a hazard

Refer to your local Health & Safety standards

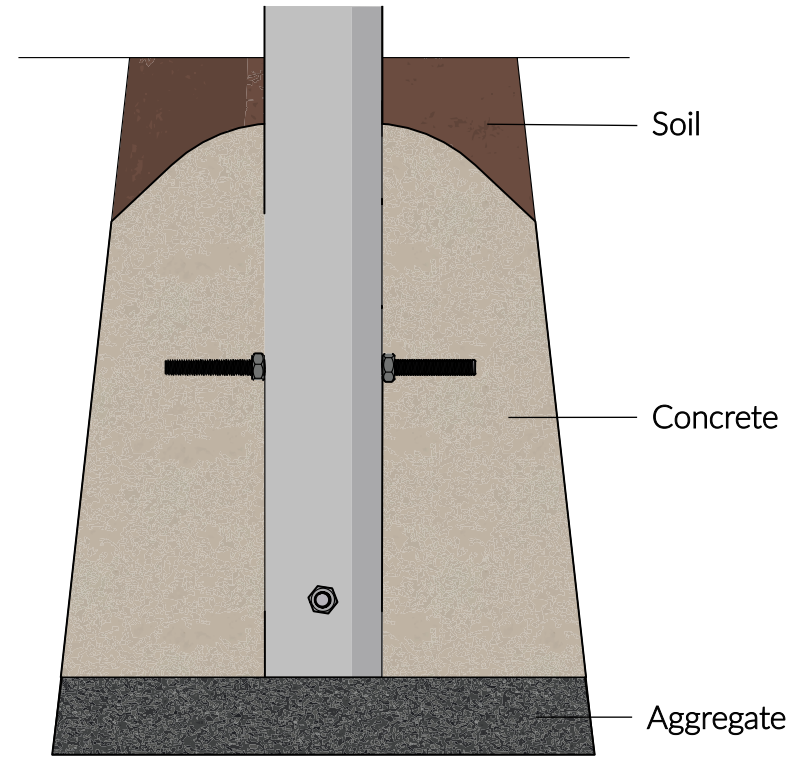
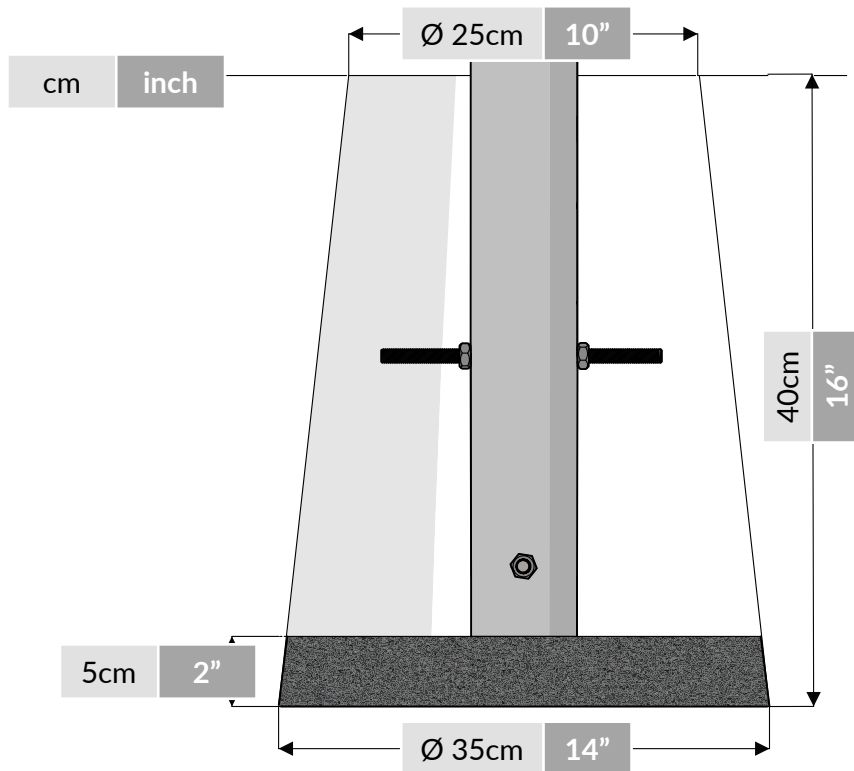
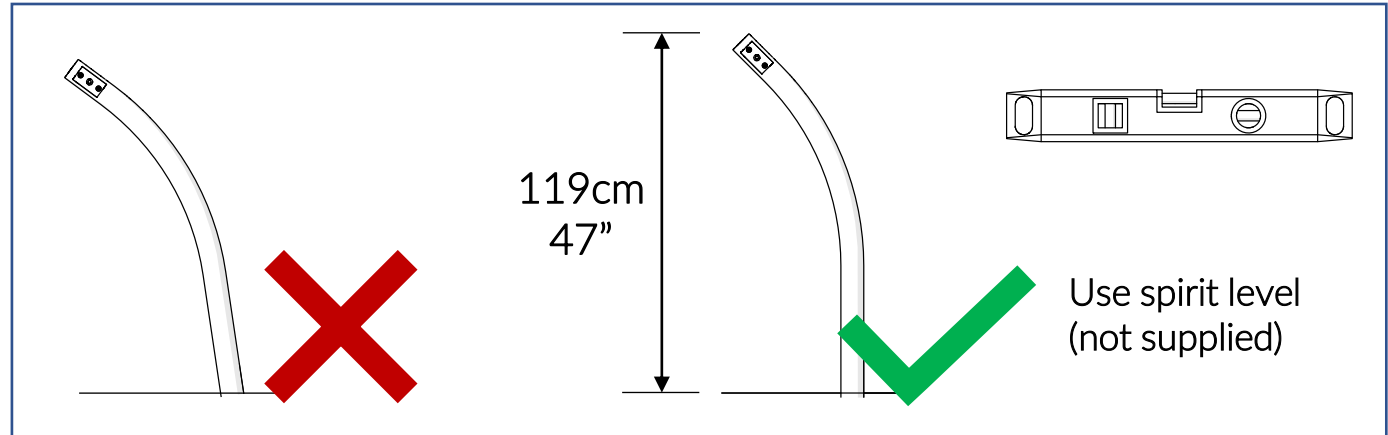

3.

3.1

3.2

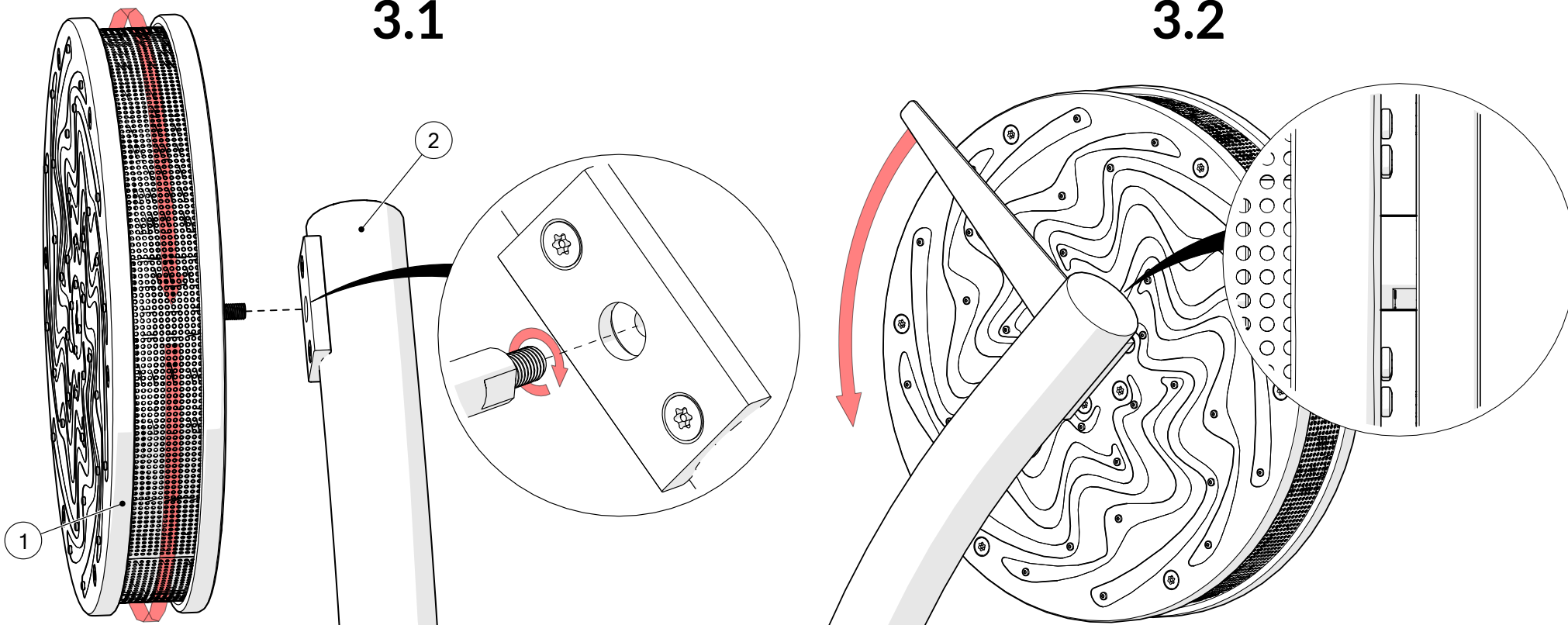

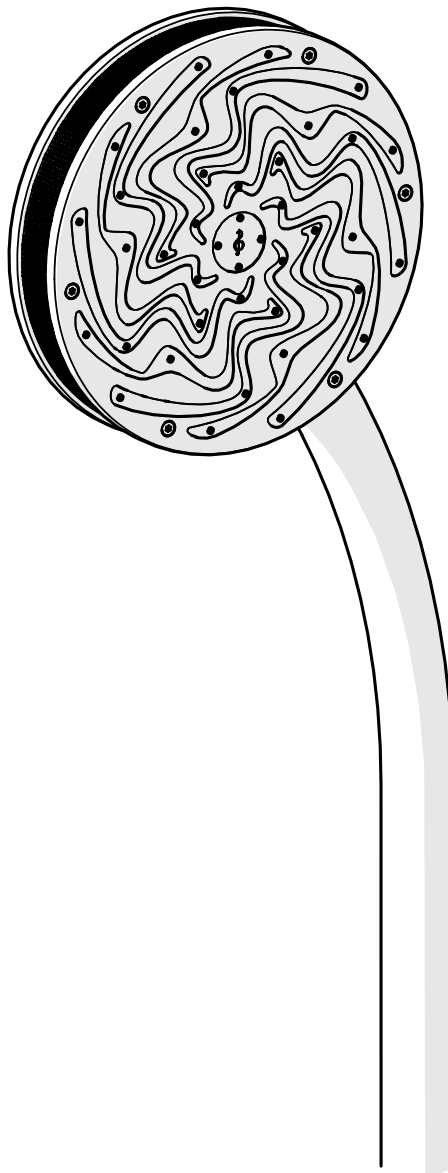

percussionplay.com



info@percussionplay.com



UK
[01730 235 180](tel:01730235180)

USA & CAN
[+1 \(866\) 882 9170](tel:+18668829170)

EUR & ROW
[+44 1730 235 180](tel:+441730235180)