

Installation Instructions

Surface Fixed

Tubular Bells
Page 1 of 2



Instrument Components:

Tubular Bells are pre-assembled

Metric Conversion:
250mm/ 10"
400mm/ 16"
600mm/ 24"
1.5m/ 59"
2207mm/ 98"

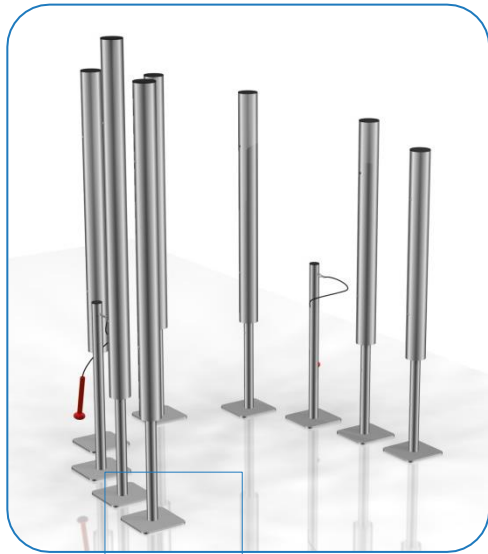

Weight of heaviest part 10kg (XXL Bell)

1. Attach Surface Fixing plates to each of the 9 legs(1.2)

2. Locate each chime in desired location and mark holes to fix to desired surface.

3. Fix Surface Plate to level surface using Coachscrews, Rawlbolts, chemical anchors or similar as deemed appropriate by Installer.

(It is your responsibility to ensure that the existing surface is suitable to receive the appropriate fixing)

4. Make sure all fixings are covered and secure using cover caps provided

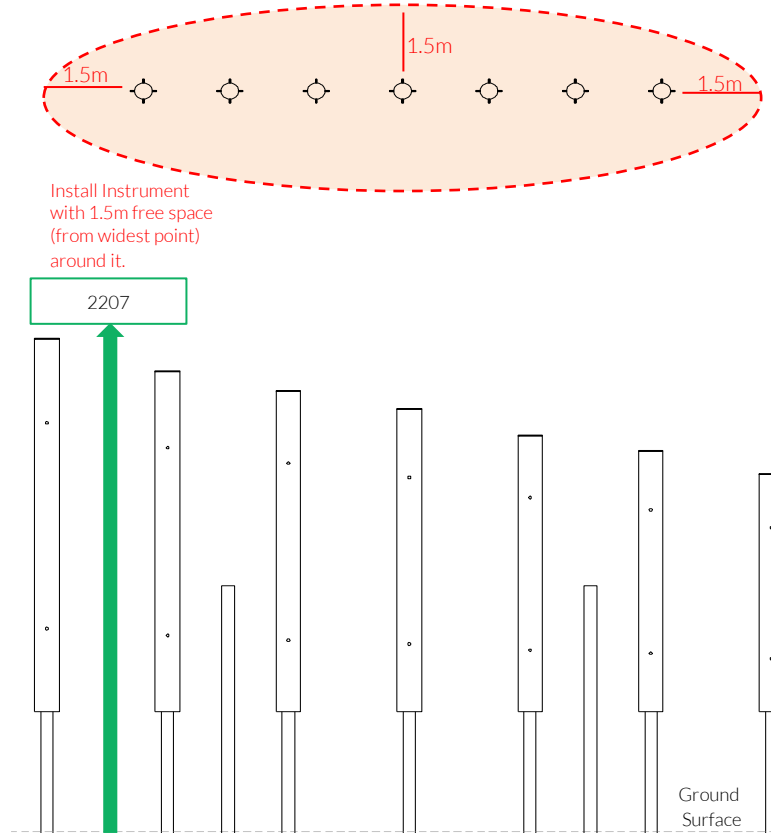

Surface Fix Components:

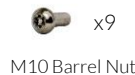

Spares available from percussionplay.com or from your local distributor

59 Kg

Surface Fixed

Tubular Bells
Page 2 of 2



Components:



x9

M10 Barrel Nut



x9

M10x40 Security Screw



x8

2 Part Cover Cap

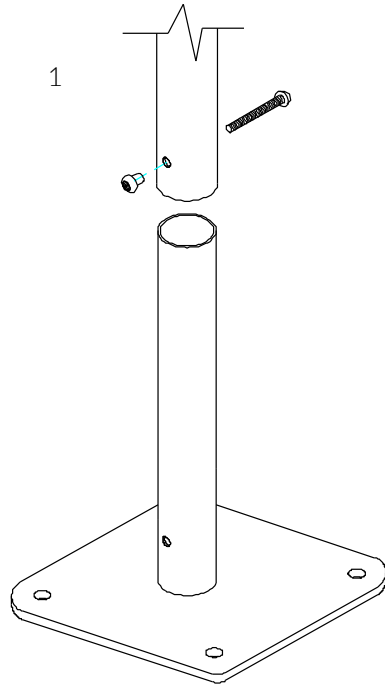

1
Locate the Surface fix Plate into the leg of the instrument.

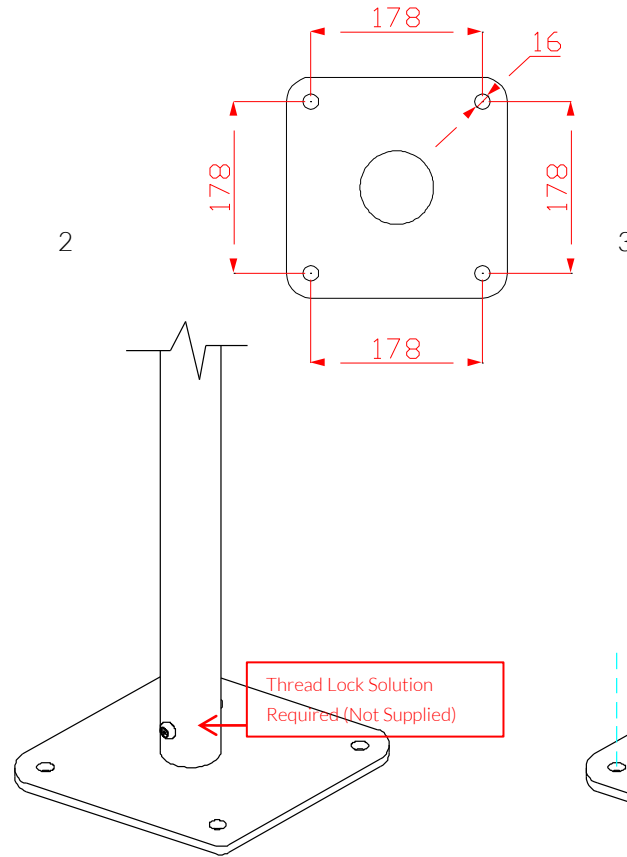

2
Fix instrument to Surface fix plate using M10 bolt and Barrel Nut and use **thread locking solution** to prevent fixings working loose.

Thread Lock Solution
Required (Not Supplied)

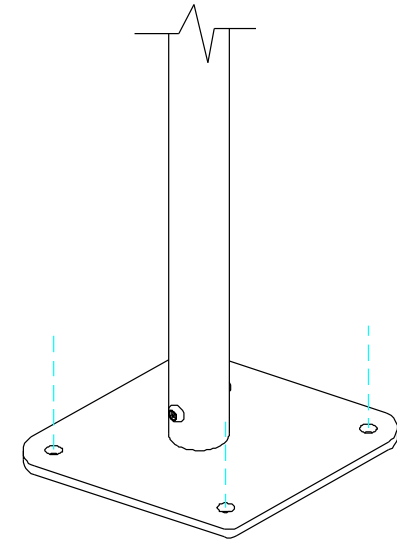

3
Fix Surface Plate to the ground surface **Ground Anchors Not provided** cover fixings with caps provided

Repeat Parts 1-3 for all 9 legs



MADE IN
BRITAIN

BSEN 1176

