

Installation Instructions

Ground Fixed
Harmony Bells
Page 1 of 4

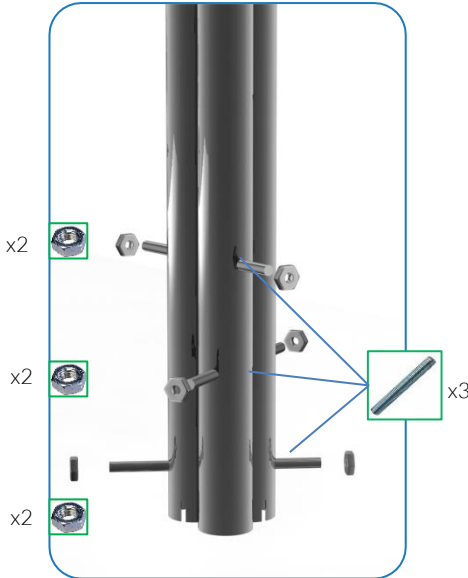
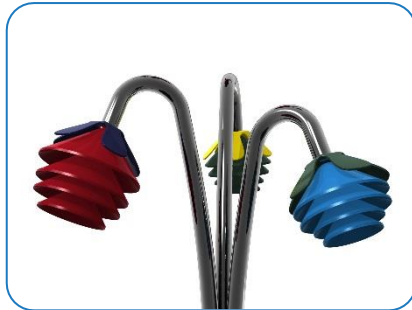

Weight of heaviest part **8Kg** (Large Bell)

Metric Conversion:
400mm/ 16"
1650mm/ 64 61/64"
1.5m/ 59"

1. Lay packaging out on floor and clear workspace with non-abrasive surface for assembly to prevent marking of polished stainless steel.

2. Unpack ground fixing extensions.

3. Cluster extensions together with M10 tapped holes facing outward and ground fixing holes aligned (**See Page 3**). Insert M10x200mm threaded bars into ground fixing holes and secure loosely with M10 BZP nuts.

4. Unpack Bell Flowers and posts.

5. Screw Bell Flowers on to their respective posts (**See Page 2**).

6. Sleeve each post over an extension (clustered) and secure with an M10x40 Screw. Ensure their orientation and configuration is correct before tightening.

7. Excavate a hole for the frame **250mm diameter, tapering down to 350mm, 450 deep** in desired location upon decision from customer.

2. Fill bottom 50mm of hole with compressed aggregate.

9. Locate (lower) frame into hole making sure that the flowers are level and upright. **Do not bury the bolt and barrel nut holes.**

10. Once happy with location of the Bells, **fill** hole using rapid hardening **concrete**. Be sure to compact concrete around legs and leave to dry according to manufactures guidelines.

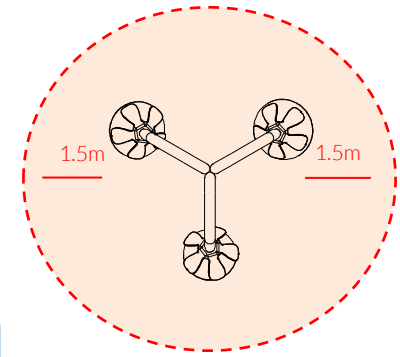

Install Instrument with 1.5m free space (from widest point) around it.

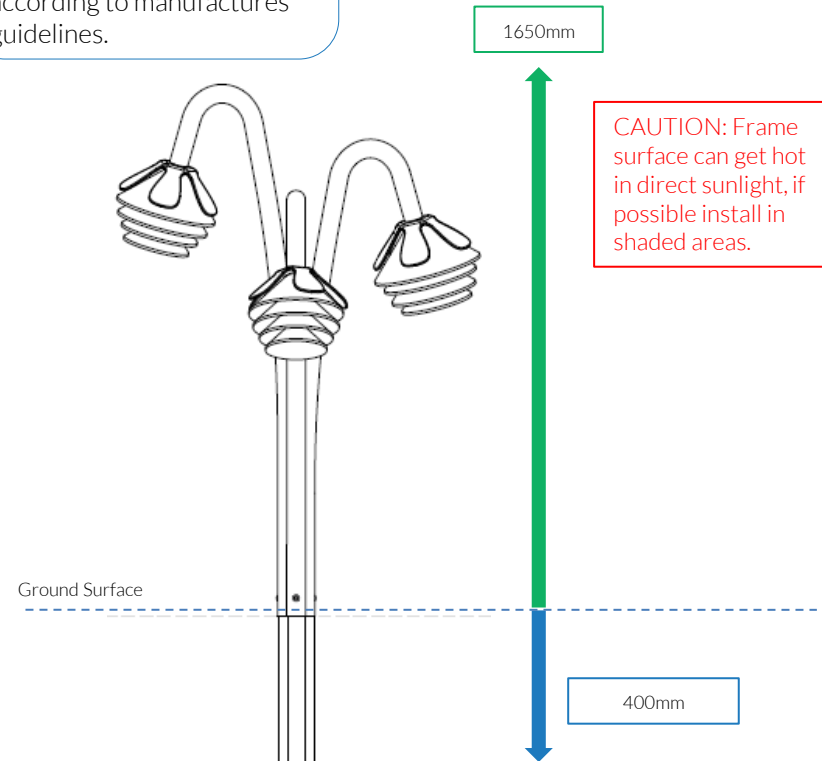

CAUTION: Frame surface can get hot in direct sunlight, if possible install in shaded areas.



Small Beaters X3

Ground Fix Components:



x3
M10x200 Threaded bar

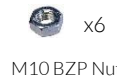

x6
M10 BZP Nut



Spares available from percussionplay.com or from your local distributor

24 Kg

Installation Instructions

Remove nylon nut and 40mm spacer to expose threadlocker, and screw bell into post.

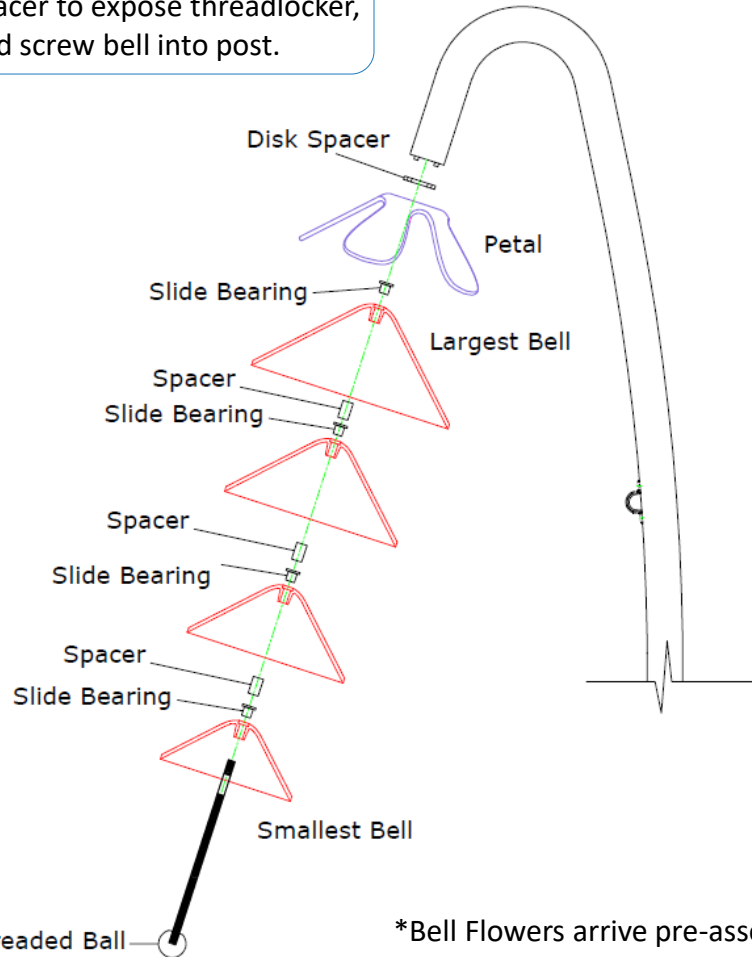

PETAL & BELL COLOUR COMBINATIONS

Major Posy

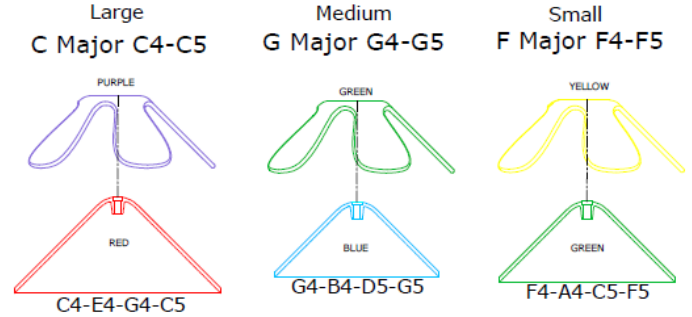

Minor Posy

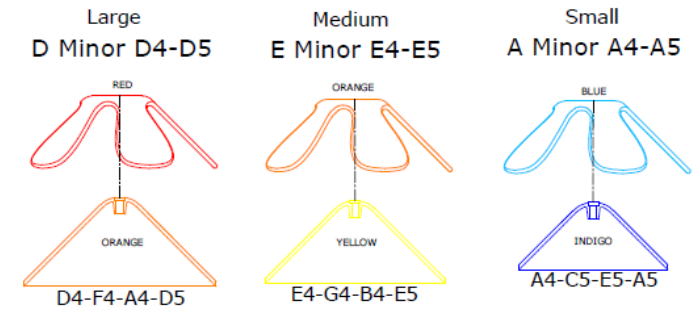

Ground Fixed

Harmony Bells
Page 2 of 4



Components:



Small
Beaters X3



Tools:
 x1
 TX 45 Driver Bit

Ground Fixed

Harmony Bells
Page 3 of 4



Components:



1.

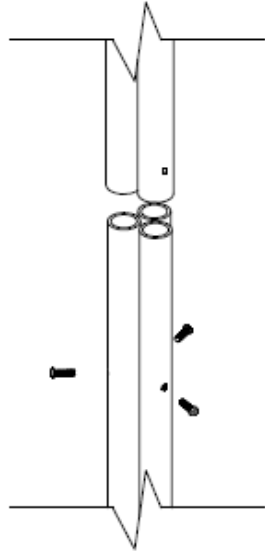

2.

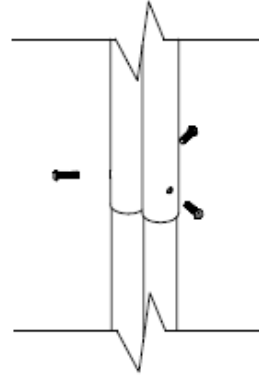

3.

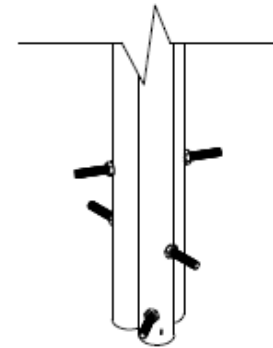
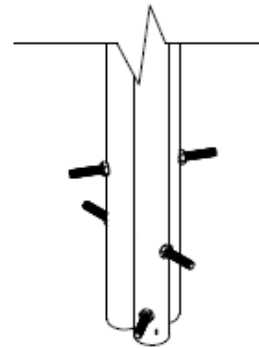
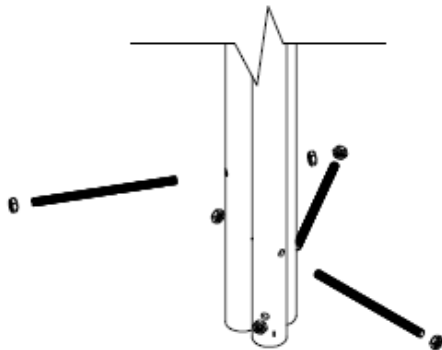
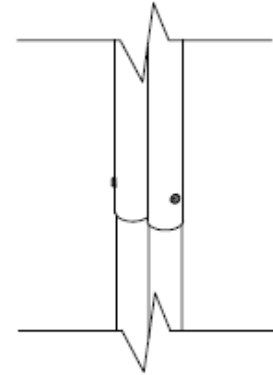

Small
Beaters X3

Ground Fix
Components:

 x3
M10x200 Threaded bar

 x6
M10BZP Nut



Spares available from
percussionplay.com or from your
 local distributor

24 Kg

Ground Fix Installation

1. Excavate a hole with a 250mm diameter tapering down to 350mm diameter and 450mm depth.

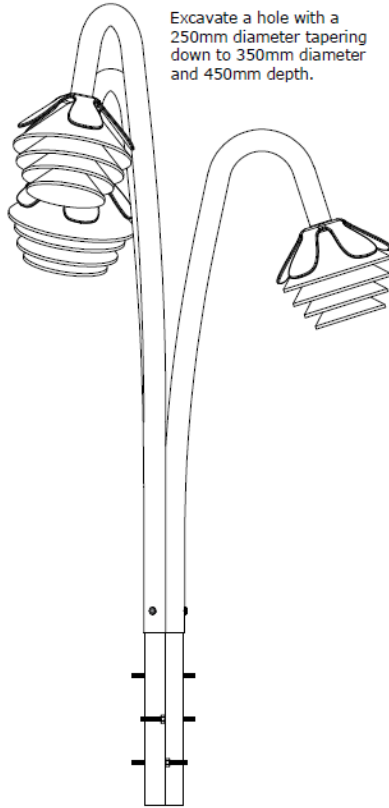

2. Compact base of hole with 50mm of aggregate. Lower ground Fix post attached to instrument into hole (check instrument straight and level before filling with concrete), ensuring 50mm of clearance between the ground and the bolt & barrel nut holes.

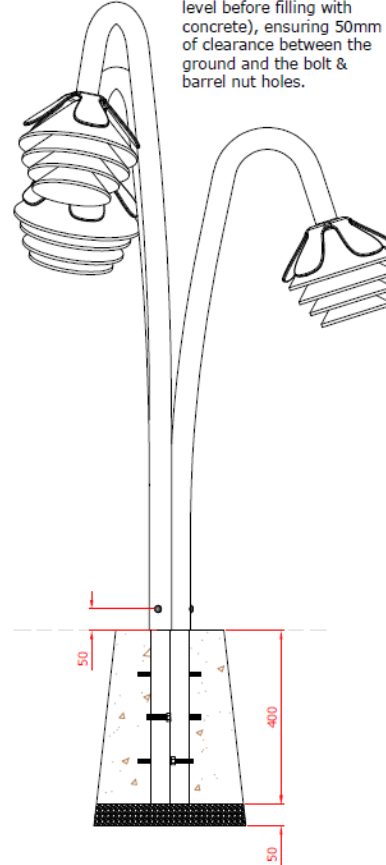

3. Fill hole with fast drying concrete to manufacturers specifications.

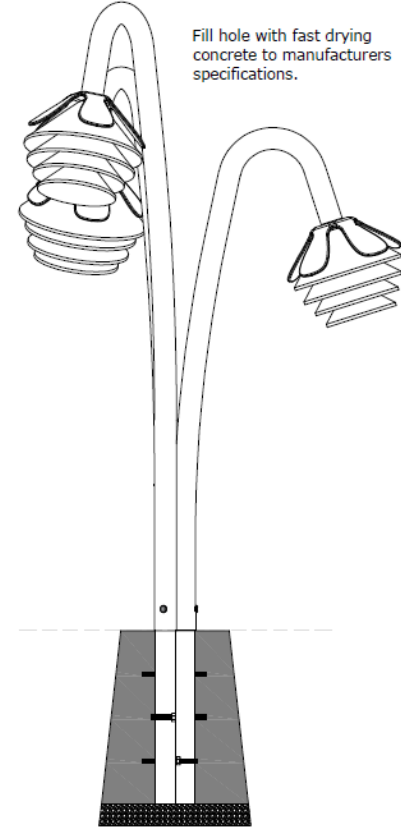

If Flower needs to be positioned lower a deeper hole can be excavated.

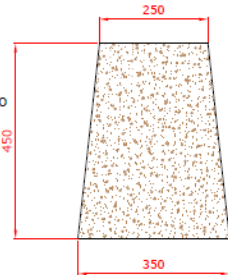

Ground Fixed

Harmony Bells
Page 4 of 4



Components:



x3

M10x200 Threaded Bar



x6

M10 BZP Nut

Metric Conversion:

50mm/ 2"
250mm/ 10"
350mm/ 14"
400mm/ 16"
450mm/ 18"

Foundations should not present a hazard. These foundations are recommended as a guide, for more information on foundation details for various surface see Part 1 of BS EN 1176.

